

Round or Square Type Non-IC Down Light Housing with Electronic Transformer for Flangeless Trims

E3_L_-HDNE_

1.7



HALOGEN MR16 - ROUND/SQUARE FLANGELESS



This product can be dimmed with a standard electronic dimmer.

This instruction shows a typical installation.

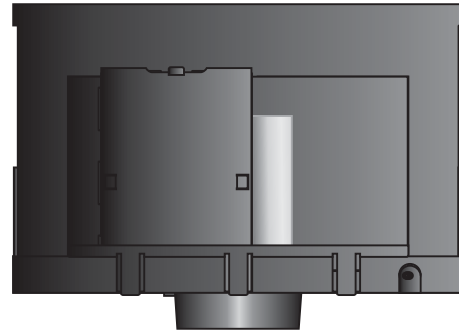

CAUTION - RISK OF FIRE

This product must be installed in accordance with the applicable installation code by a person familiar with the construction and operation of the product and the hazards involved.

Use minimum 90°C supply conductors.

Install the Housing with Adjustable Bars

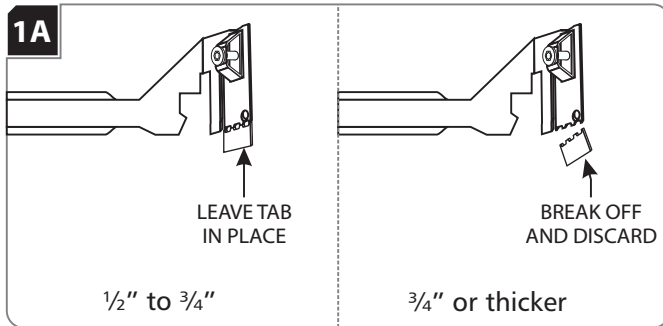

NOTE: Skip this section if installing the housing with butterfly brackets.

- 1** **Keep Tab for ceiling 1/2" to 3/4" thick.**
 When using adjustable hanger bars with 1/2" to 3/4" thick ceilings, leave the tab of the hanger bars in place.
Break off Tab for ceiling 3/4" or thicker.
 When using adjustable hanger bars with 3/4" or thicker ceilings, remove the tab by bending it at the perforation.

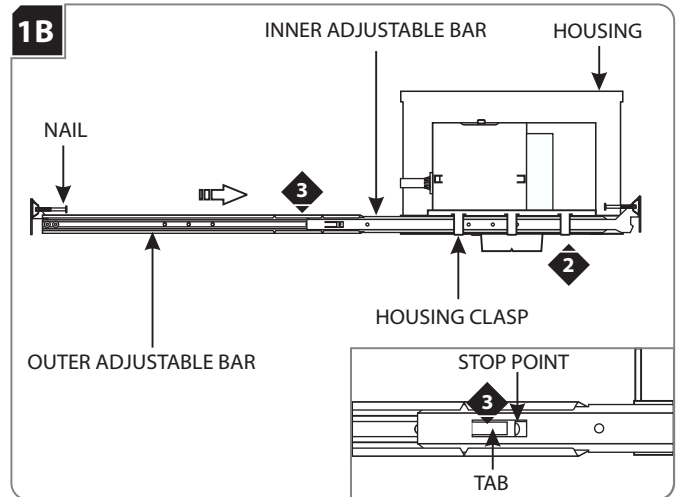

- 2** Slide the inner adjustable bar completely through the three housing clasps. Make sure the nail is on top.
- 3** Slide and push the outer adjustable bar completely onto the inner adjustable bar so that the tab clicks into place behind the stop point. This will prevent the adjustable bars from coming apart.
- 4** Repeat steps 2 & 3 for the other side of the housing.

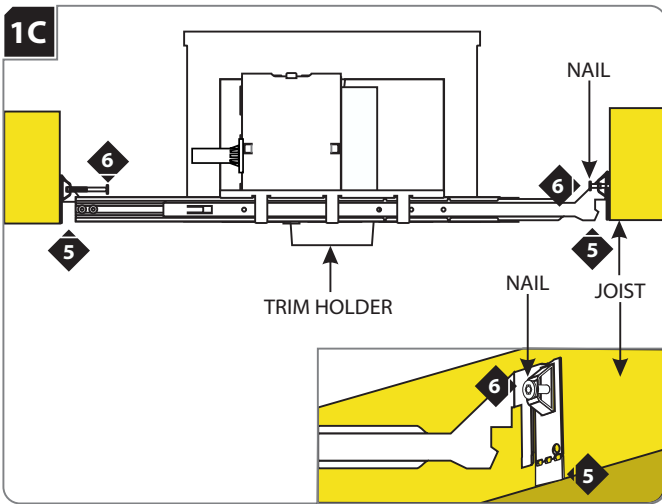

NOTE: The adjustable bars can be mounted to joists that are spaced 16" - 24" apart.

- 5 Align the bottom of the end plates with the bottom of the ceiling joists.
- 6 Level the adjustable bars and, with a hammer, tap the nails completely into the joists to secure the adjustable bars.

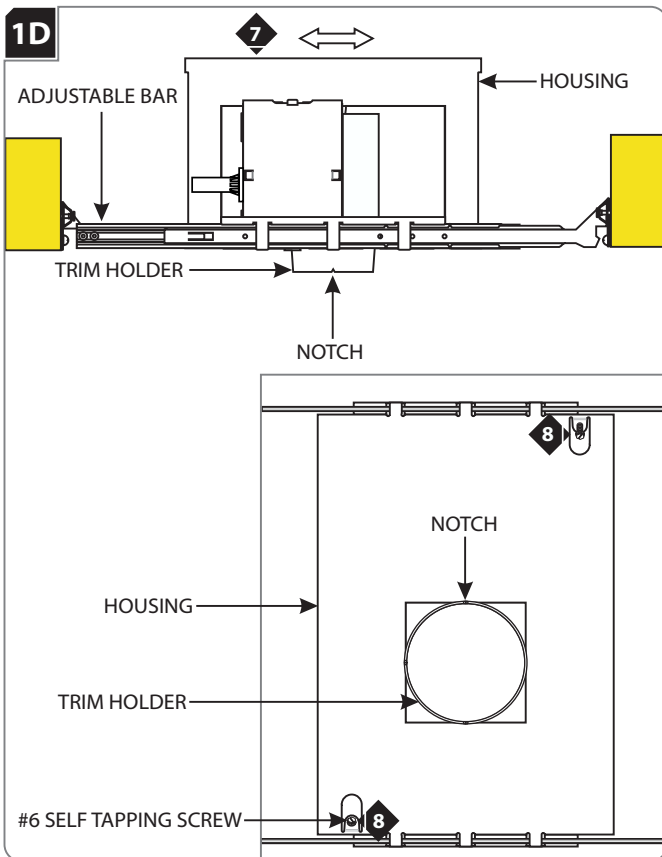

- 7 Adjust the trim holder position (horizontal position) by sliding the housing on adjustable bars.
- 8 When the desired location is achieved, tighten the two #6 self tapping screws to lock the housing onto the adjustable bars.

NOTE: Notches in trim holder can be used to align multiple housings using a laser or string.

Install the Housing with Butterfly Brackets

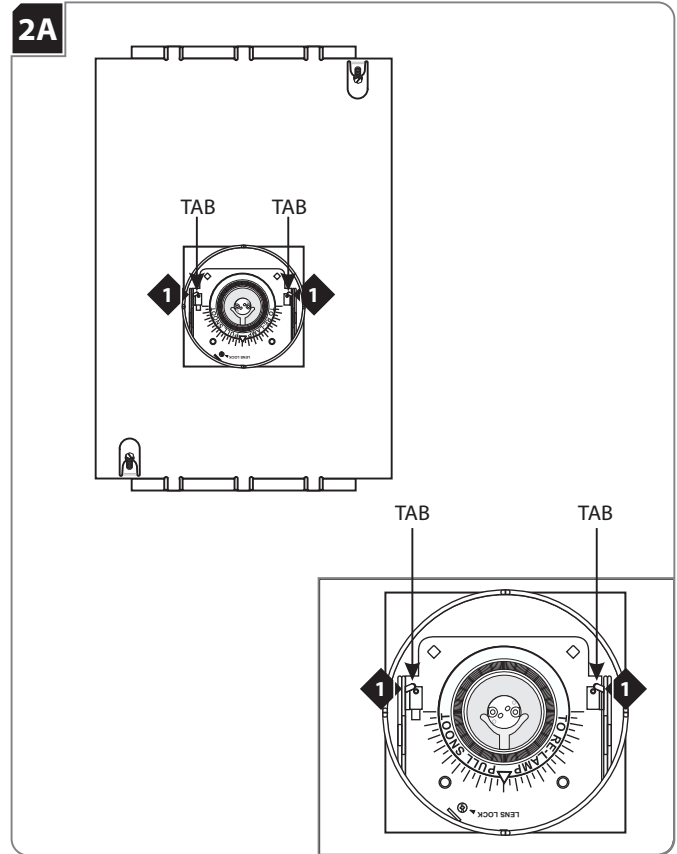

NOTE: Skip this section if installing the housing with butterfly brackets.

- 1 Squeeze the two tabs on the lamp housing to unsnap it.
- 2 Swing the lamp housing back.

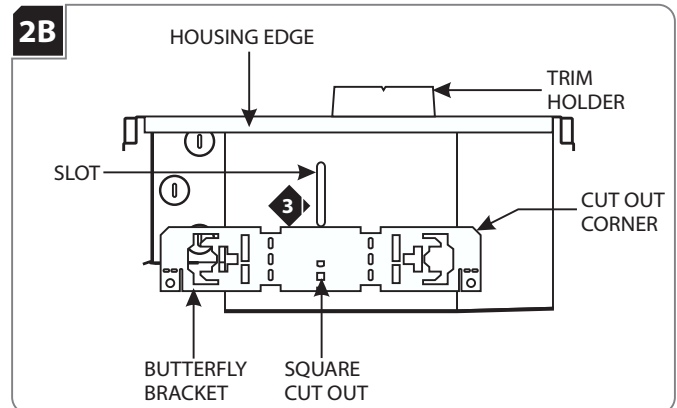

- 3 Line up the square cut out section of the butterfly bracket with the housing slot. Make sure the cut out corner of the butterfly bracket is against the housing edge.

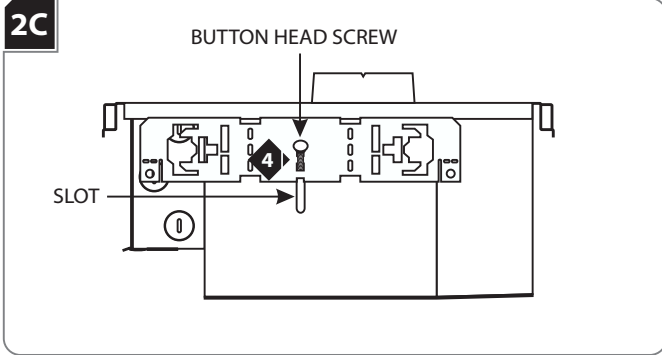

- 4 Place the button head screw through the square cut out of the butterfly bracket into the housing slot.

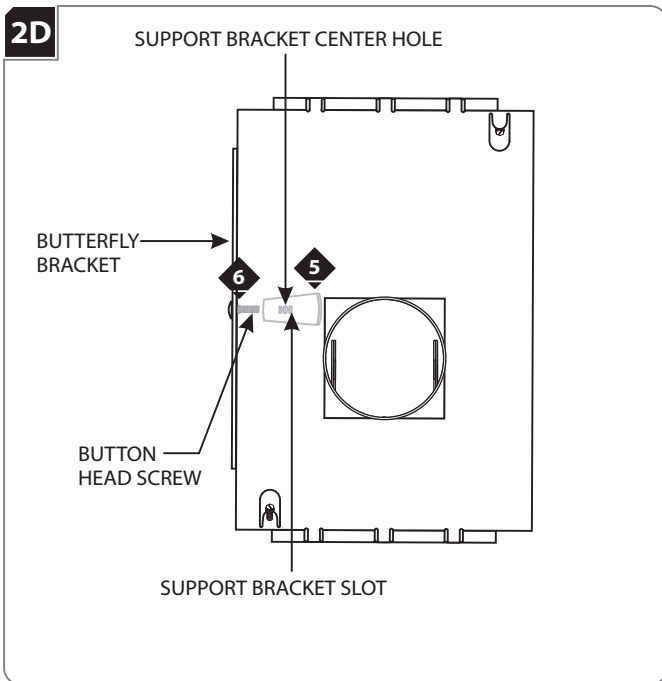

- 5 Place the support bracket center hole onto the button head screw.
- 6 Push the support bracket slots against the butterfly bracket tabs.

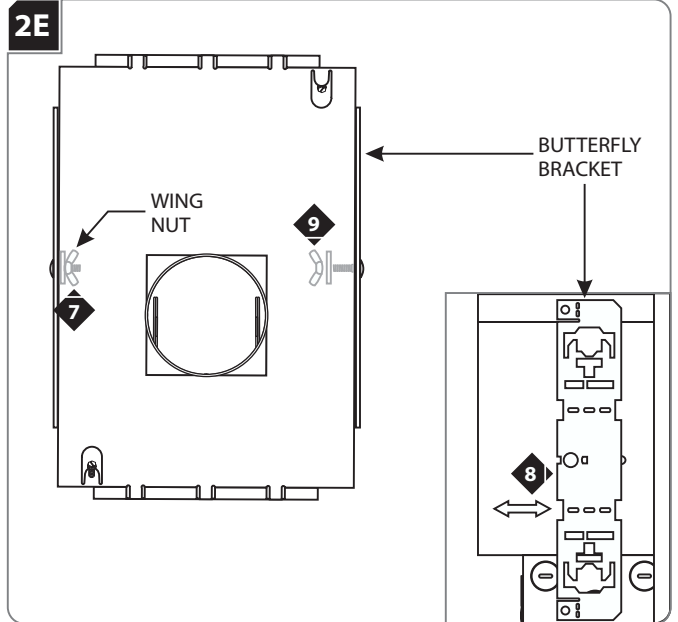

- 7 Tighten the wing nut (**Not Completely**) to the button head screw threads.
- 8 Slide the butterfly bracket up or down to achieve the proper location. Tighten the wing nut to secure the butterfly bracket in place.
- 9 Repeat steps 3 through 8 on pages 2 and 3 for the other butterfly bracket.

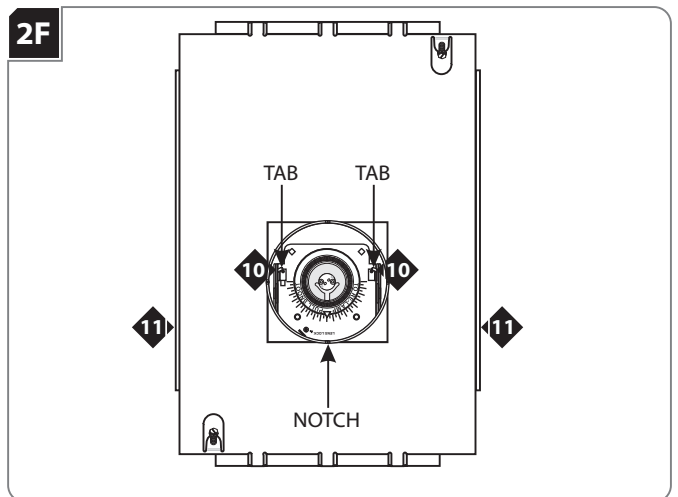

- 10 Swing the lamp housing down until the tabs lock it in place.
- 11 Utilize the butterfly brackets to install the housing in accordance with local electrical codes.

NOTE: Notches in trim holder can be used to align multiple housings using a laser or string.

- 12 Follow "Connect Power to the Housing" on page 4.

Connect Power to the Housing

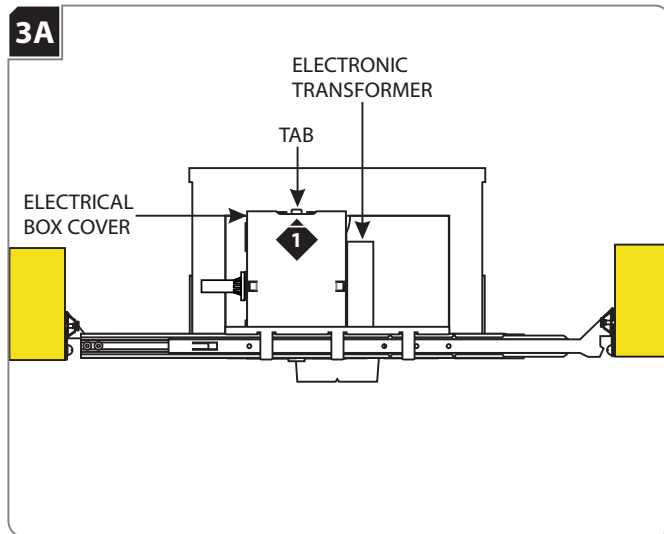

- 1 Push the tab on the housing electrical box up and remove the electrical box cover.

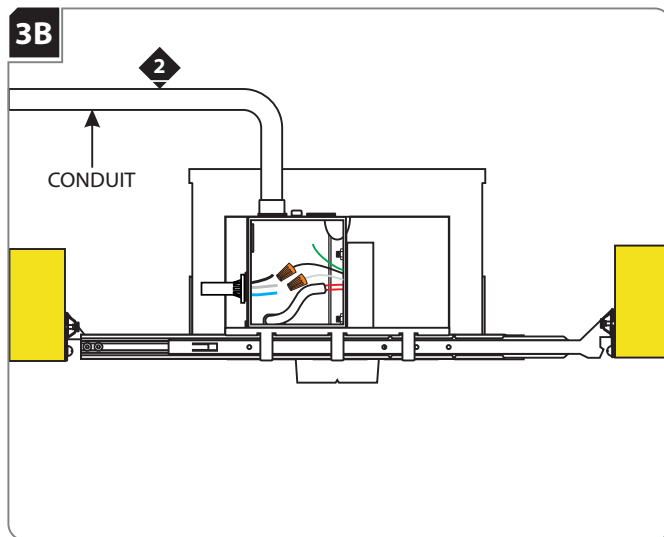

- 2 Install the conduit to the housing electrical box.

WARNING: RISK OF FIRE: When using the housing electrical box for power feed through, use **MAX** 4 - #12 AWG, or 6 - #14 AWG branch circuit wires.

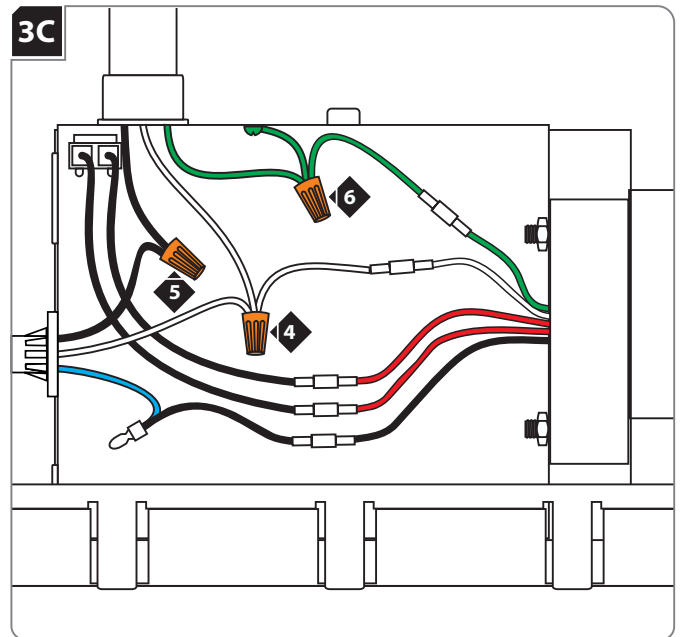

- 4 Connect the neutral power line wire to the white transformer wire and the white thermal protector wire with the wire nut.
- 5 Connect the hot power line wire to the black thermal protector wire with the wire nut.
- 6 Connect the fixture ground wire and the green transformer wire to a suitable ground according to local electrical codes.

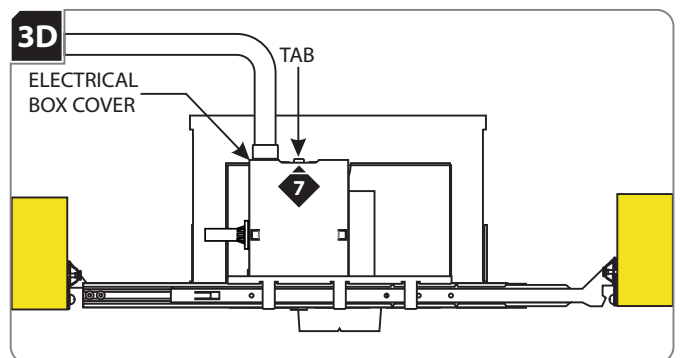

- 7 Replace the electrical box cover. Make sure that the top edge of the cover snaps under the tab.

Install the Lamp & Lens Accessories

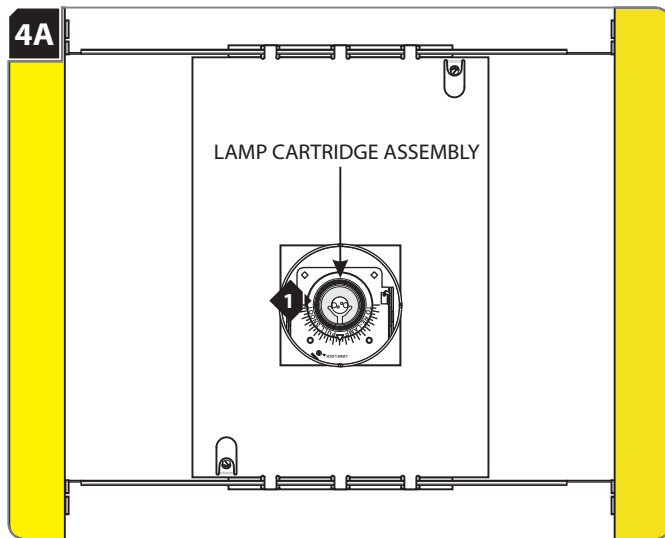

- 1 Pull the snout to remove the lamp cartridge assembly.

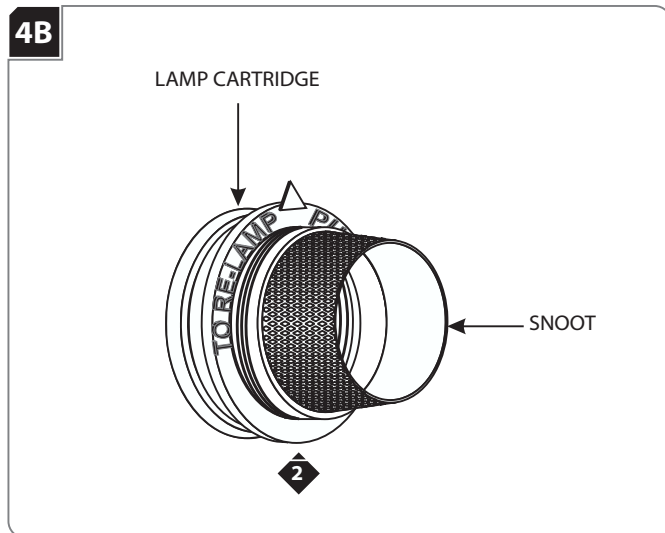

- 2 Unscrew the snout from the lamp cartridge.

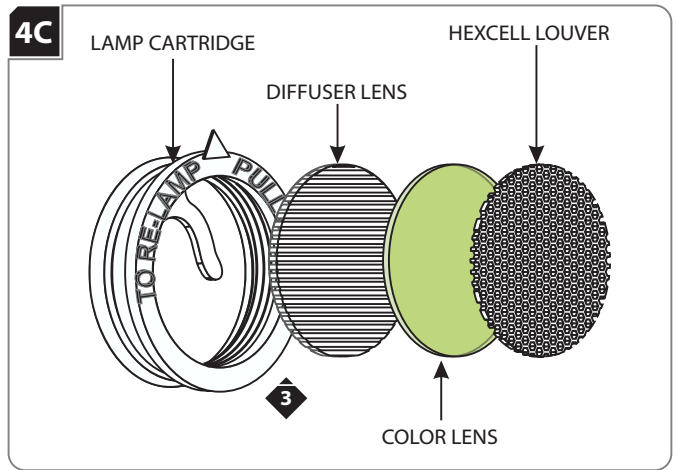

- 3 Place a maximum of three accessories (optional) into the lamp cartridge.

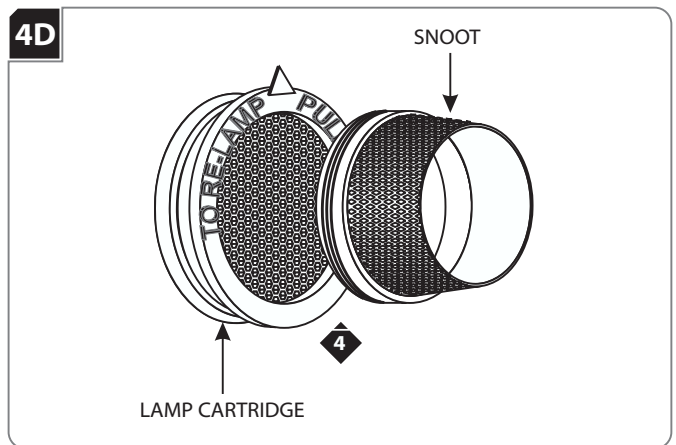

- 4 Replace and tighten the snout completely to the lamp cartridge.

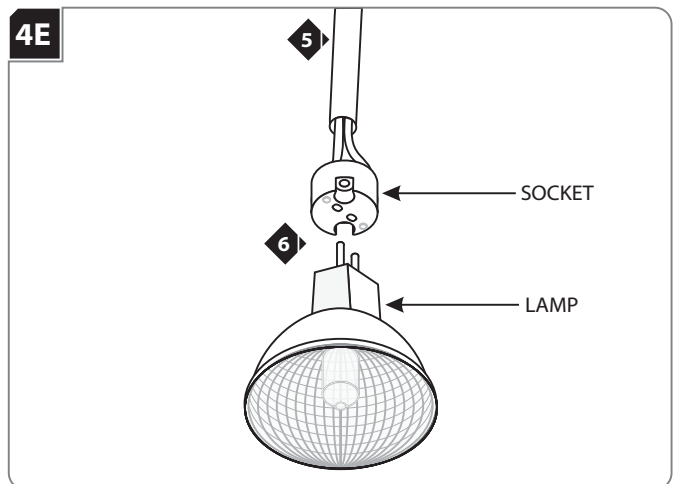

Use **MAX 75 Watt** Type MR16 Halogen Lamp.



- 5 Pull out the socket from the lamp housing.
6 Push the lamp pins completely into the socket holes.

Install Drywall and Plaster Ring

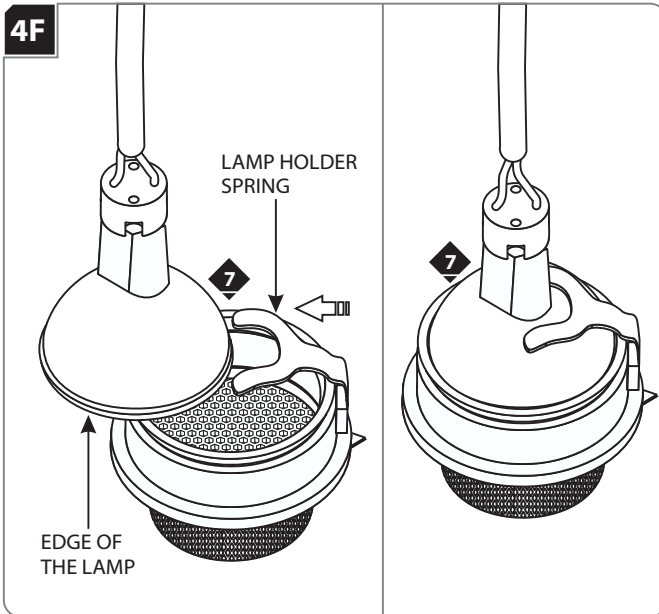

- 7 Slide the lamp holder spring completely onto back of the MR16 lamp so that the edge of the lamp snaps into the lamp cartridge assembly.

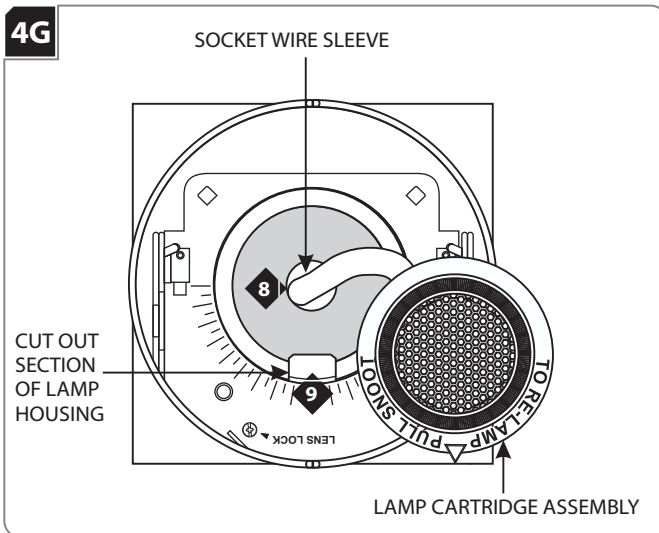

- 8 Feed the socket wire sleeve back into the lamp housing.
- 9 Align the arrow indicator on the lamp cartridge assembly with the cut out section of the lamp housing. Push to snap the lamp cartridge assembly into the lamp housing.

NOTE: Before installing drywall, it is recommended to power up and run the Element fixture(s) for 10 minutes to make sure that all electrical connections are tight and secure.

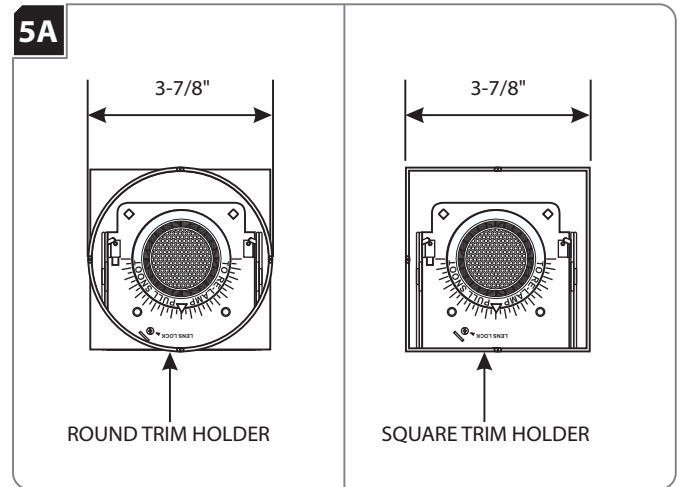

- 1 For round trims, mark a 3-7/8" diameter circle on drywall. Cut out the marked section. For square trims, mark a 3-7/8" square on drywall. Cut out the marked section.

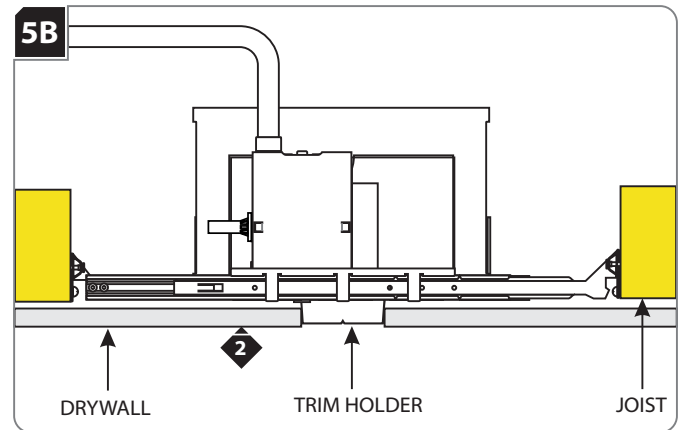

- 2 Align the cut out section of drywall with the trim holder and install the drywall.

WARNING: Risk of Fire: The housing is not intended to be in contact with or covered with combustible materials and insulation. Do not install insulation within 3 inches of the housing sides or above in such a manner to entrap heat.

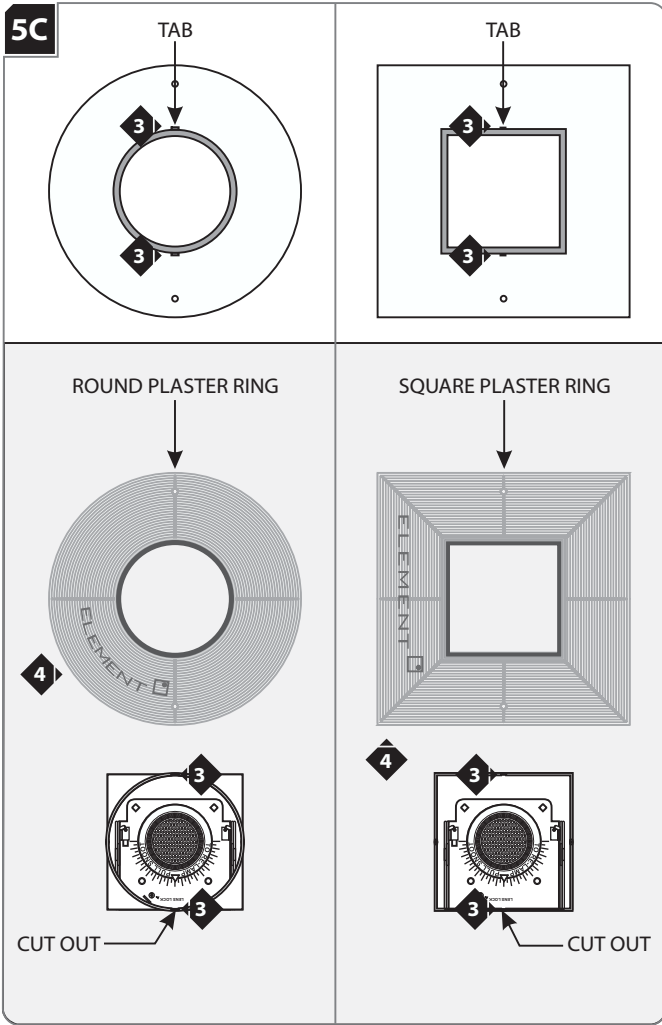

- 3 Line up the two tabs in back of the plaster ring with the two cut out sections of the trim holder inside edge.
- 4 Push the plaster ring tabs into the cut out sections of the trim holder edge.

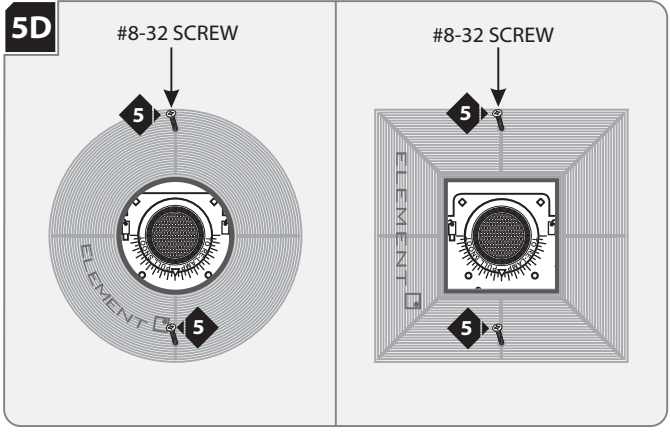

- 5 Secure the plaster ring in place with the two provided flat head #8-32 screws. Make sure that the screws penetrate through the drywall into the housing screw holes.

NOTE: Do not overtighten the screws! Overtightening may bend the plaster ring, causing the plaster surface to come away from the drywall.

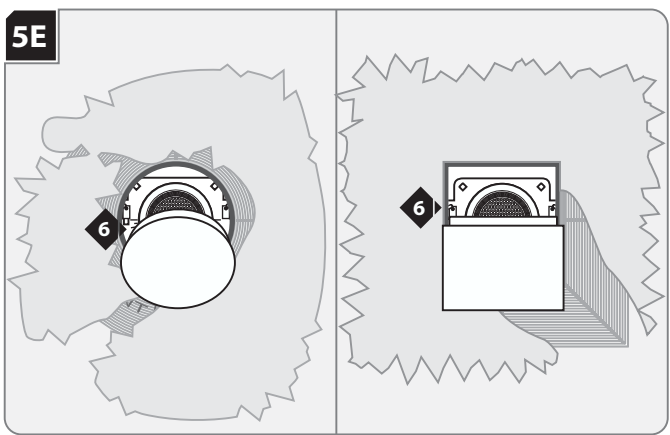

- 6 Plug the trim holder with the provided dust shield.
- 7 Properly plaster onto the plaster ring and drywall.

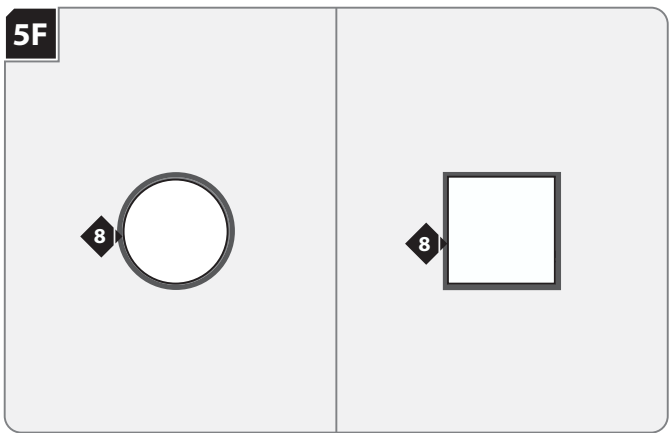

- 8 Finish around the trim to match drywall.

SAVE THESE INSTRUCTIONS!

ELEMENT 
a brand of **TECH LIGHTING**

7400 Linder Ave, Skokie, IL 60077

847.410.4400

www.element-lighting.com

© 2015 Tech Lighting, L.L.C. All rights reserved. The "Element" graphic is a registered trademark of Element. Element reserves the right to change specifications for product improvements without notification.

A Generation Brands Company