

Round or Square Type Non-IC Adjustable Housing with Remote Transformer for Flanged Trims

E3_F_-HANR_

1.7



HALOGEN MR16 - ROUND/SQUARE FLANGED

GENERAL PRODUCT INFORMATION:



This instruction shows a typical installation.

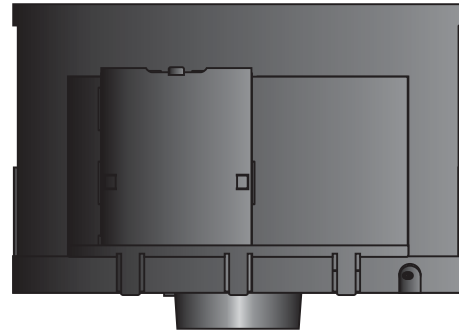

CAUTION - RISK OF FIRE

This product must be installed in accordance with the applicable installation code by a person familiar with the construction and operation of the product and the hazards involved.

Use minimum 90°C supply conductors.

Install the Housing with Adjustable Bars

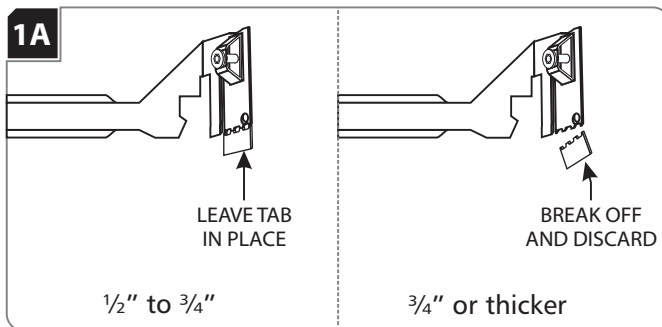

NOTE: Skip this section if installing the housing with butterfly brackets.

- 1 **Keep Tab for ceiling 1/2" to 3/4" thick.**
When using adjustable hanger bars with 1/2" to 3/4" thick ceilings, leave the tab of the hanger bars in place.
Break off Tab for ceiling 3/4" or thicker.
When using adjustable hanger bars with 3/4" or thicker ceilings, remove the tab by bending it at the perforation.

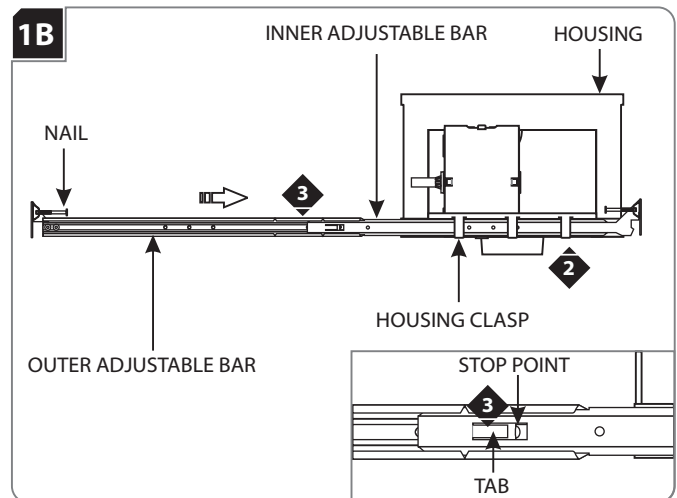

- 2 Slide the inner adjustable bar completely through the three housing clasps. Make sure the nail is on top.
- 3 Slide and push the outer adjustable bar completely onto the inner adjustable bar so that the tab clicks into place behind the stop point. This will prevent the adjustable bars from coming apart.
- 4 Repeat steps 2 & 3 for the other side of the housing.

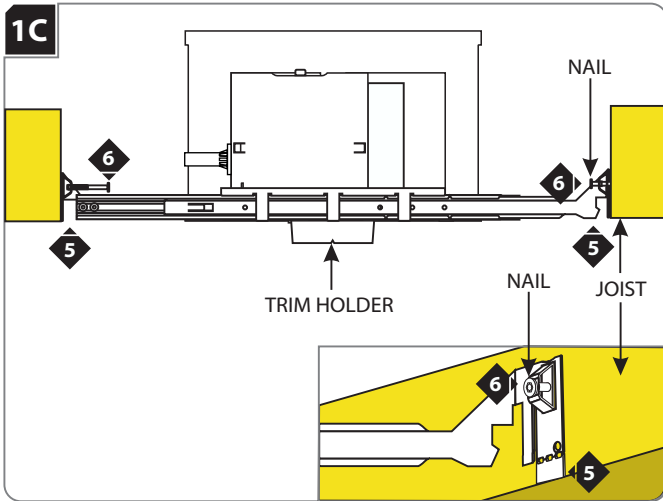

NOTE: The adjustable bars can be mounted to joists that are spaced 16" - 24" apart.

- 5 Align the bottom of the end plates with the bottom of the ceiling joists.
- 6 Level the adjustable bars and, with a hammer, tap the nails completely into the joists to secure the adjustable bars.

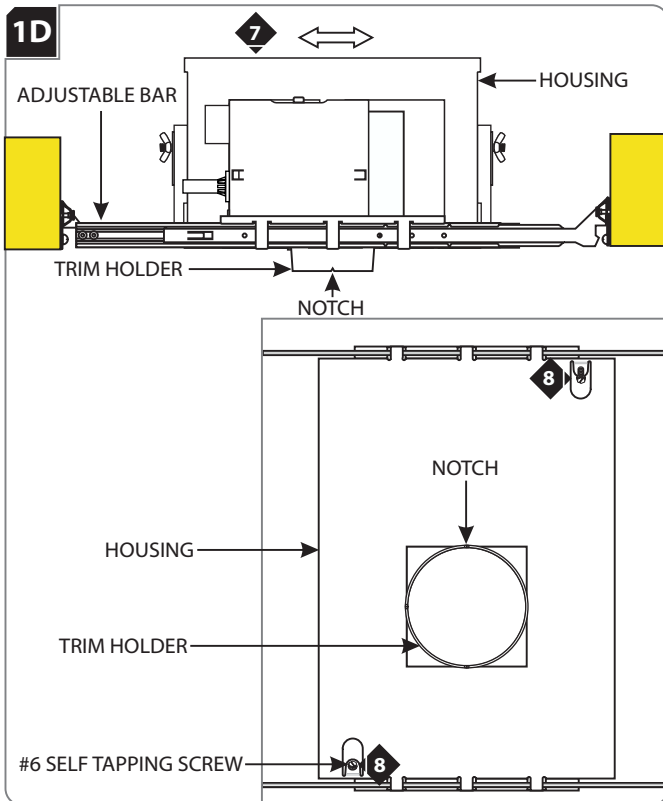

- 7 Adjust the trim holder position (horizontal position) by sliding the housing on adjustable bars.
- 8 When the desired location is achieved, tighten the two #6 self tapping screws to lock the housing onto the adjustable bars.

NOTE: Notches in trim holder can be used to align multiple housings using a laser or string.

Install the Housing with Butterfly Brackets

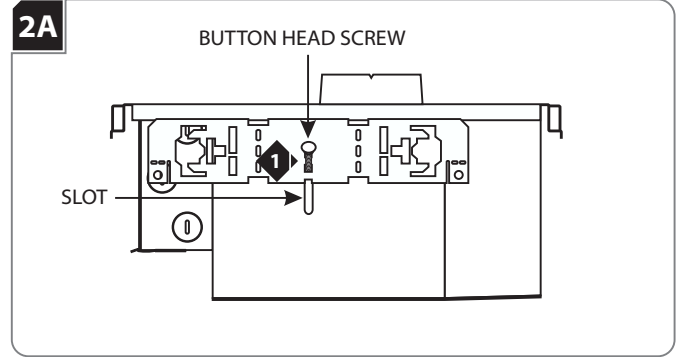

NOTE: Skip this section if installing the housing with adjustable bars.

- 1 Place the button head screw through the square cut out of the butterfly bracket into the housing slot.

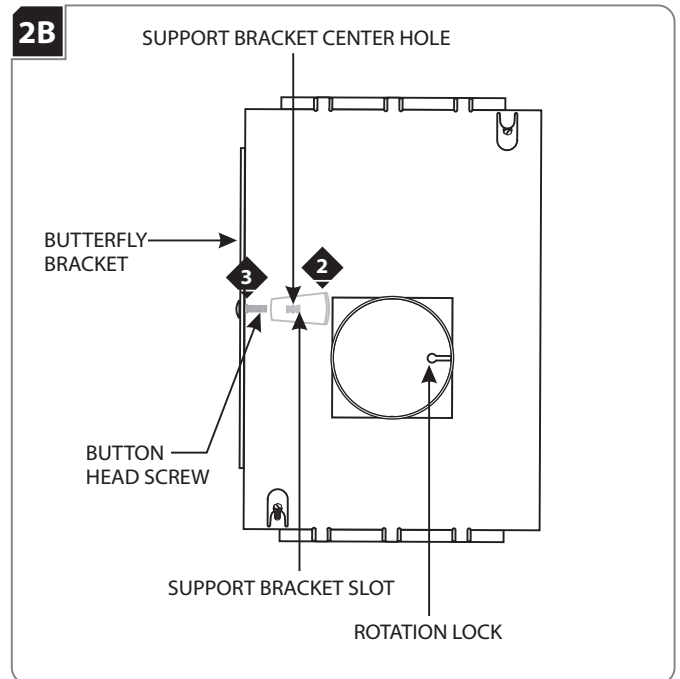

NOTE: If necessary, pull the rotation lock down to rotate the lamp housing.

- 2 Place the support bracket center hole onto the button head screw.
- 3 Push the support bracket slots against the butterfly bracket tabs.

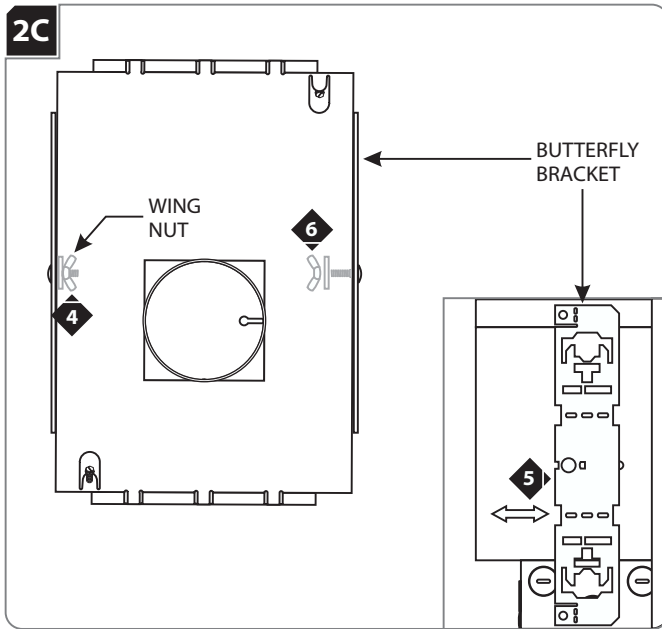
2C

- 4 Attach the wing nut loosely to the button head screw.
- 5 Slide the butterfly bracket up or down to achieve the proper location. Tighten the wing nut to secure the butterfly bracket in place.
- 6 Repeat steps 1-5 for the other butterfly bracket.
- 7 Use the butterfly brackets to install the housing in accordance with local building and electrical codes.

NOTE: Notches in trim holder can be used to align multiple housings using a laser or string.

Connect Power to the Housings

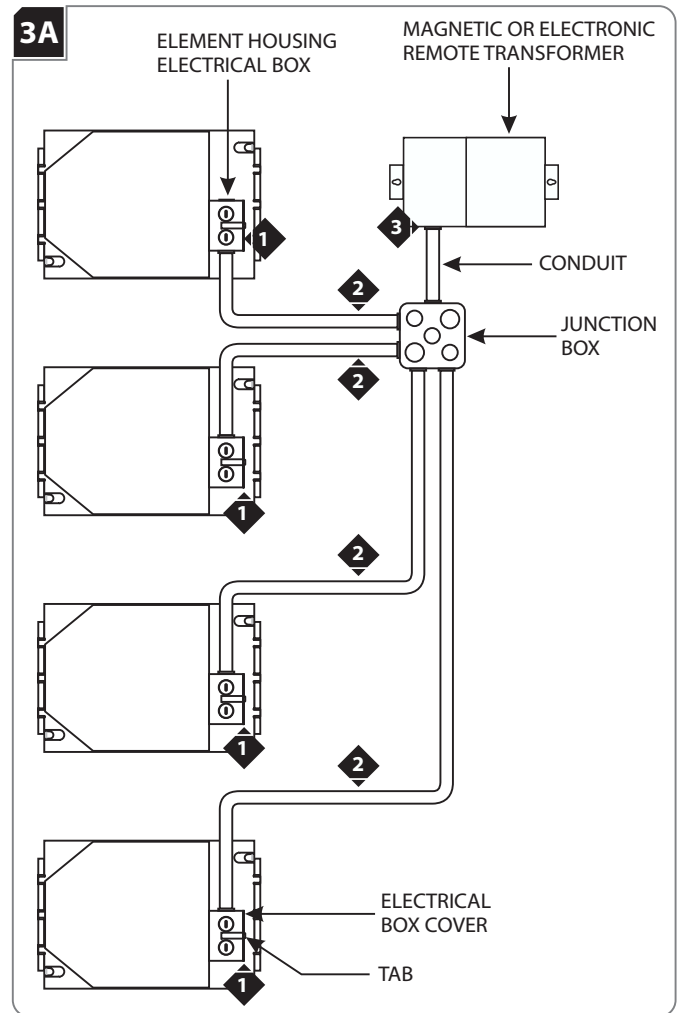
3A

- 1 For each Element housing, push the tab on the housing electrical box up and remove the electrical box cover.
- 2 Run conduits from remote transformer (via a junction box) to the each Element housing electrical box.
- 3 Branch the low voltage wires from the remote transformer (via junction box) to Element housings. For proper low voltage wire size, refer to the "Low Voltage Wire Size Table" provided in the remote transformer instruction.

WARNING: RISK OF FIRE: When using the housing electrical box for power feed through, use **MAX** 4 - #12 AWG, or 6 - #14 AWG branch circuit wires.

Install Drywall or Suspended Ceiling

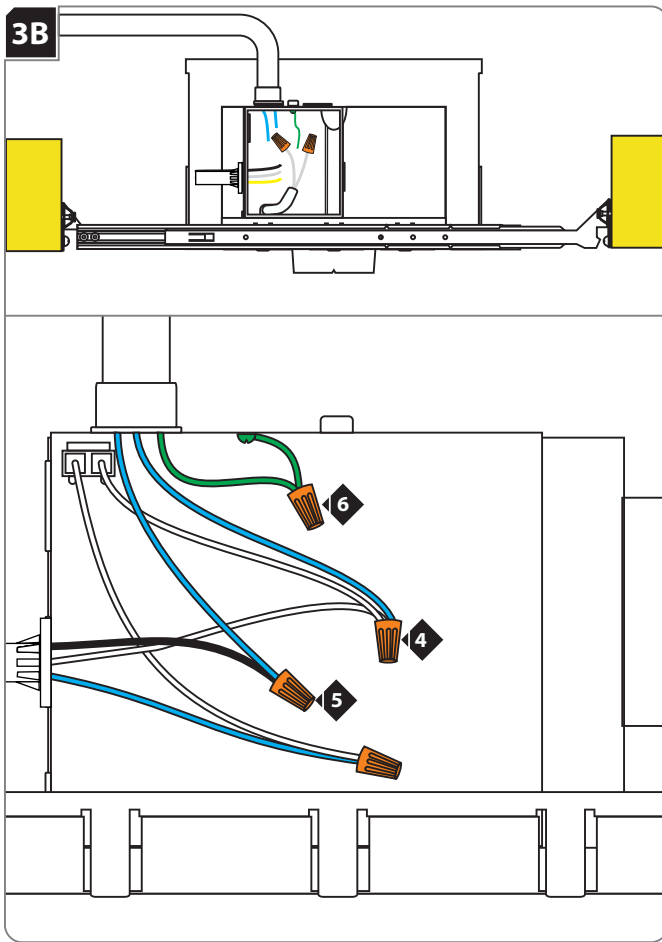

- 4 Connect one low voltage wire to one socket wire and the white thermal protector wire with a wire nut.
- 5 Connect the other low voltage wire to the black thermal protector wire with a wire nut.
- 6 Make sure that housing is grounded in accordance with local electrical codes.

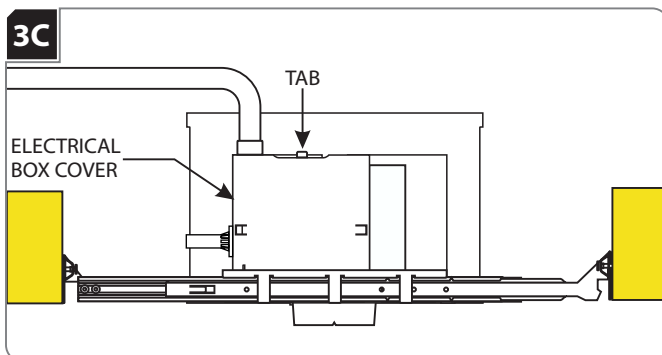

- 7 Replace the electrical box cover. Make sure that the top edge of the cover snaps under the tab.
- 8 Repeat steps 4 through 6 for the remaining Element housings.

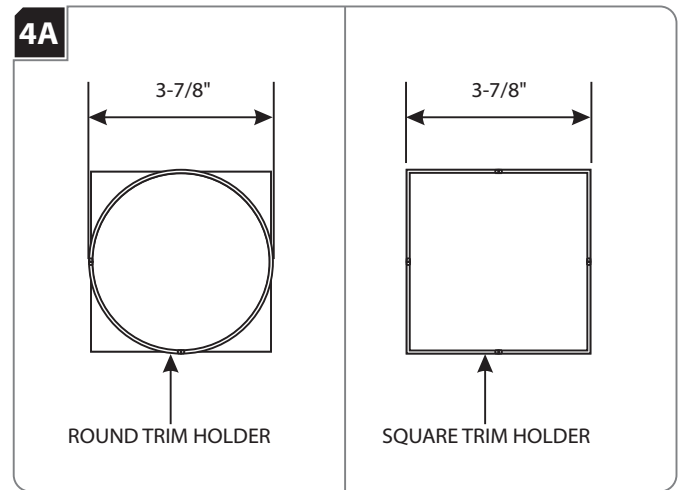

- 1 For round trims, mark a 3-7/8" diameter circle on drywall. Cut out the marked section.
For square trims, mark a 3-7/8" square on drywall. Cut out the marked section.

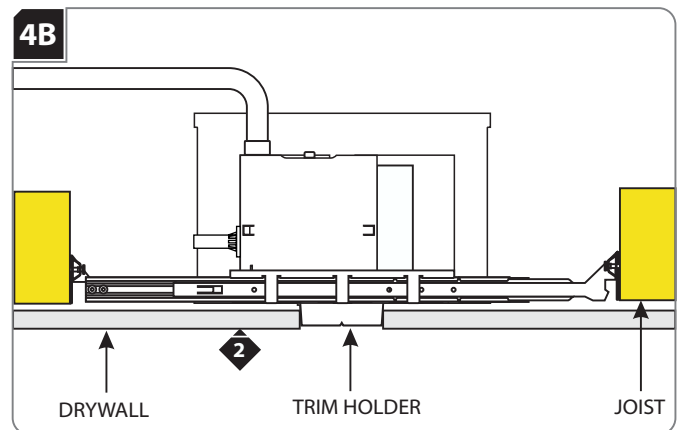

- 2 Align the cut out section of drywall with the trim holder and install the drywall.

WARNING: Risk of Fire: The housing is not intended to be in contact with or covered with combustible materials and insulation. Do not install insulation within 3 inches of the housing sides or above in such a manner to entrap heat.

Install the Lamp & Lens Accessories

5A

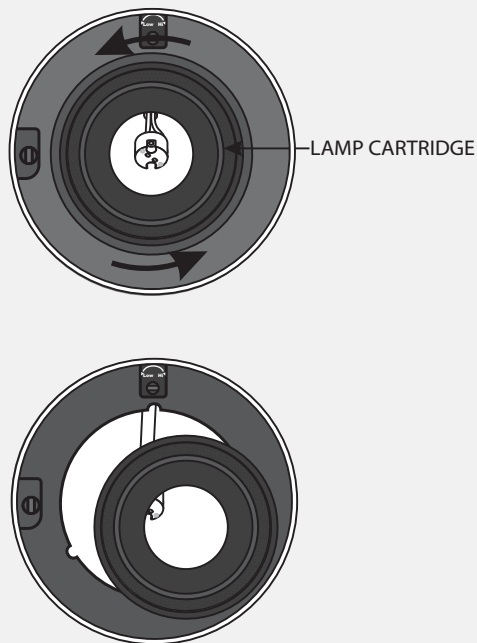

- 1 To release the lamp cartridge, rotate it counter clockwise and gently pull out the assembly.

5B

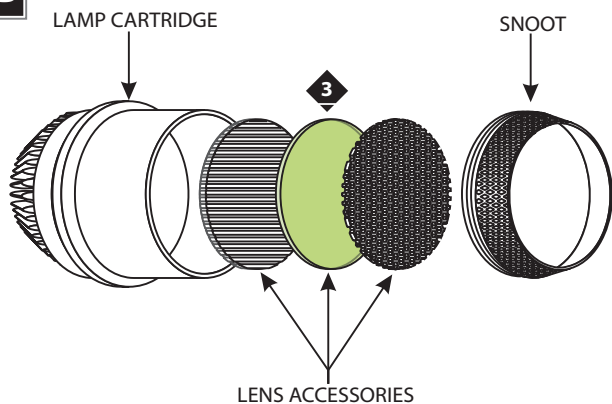

- 2 To install a lens accessory (optional), unscrew the snoot from the lamp cartridge.
- 3 Place a maximum of three accessories into the lamp cartridge.
- 4 Replace and tighten the snoot completely to the lamp cartridge.

5C

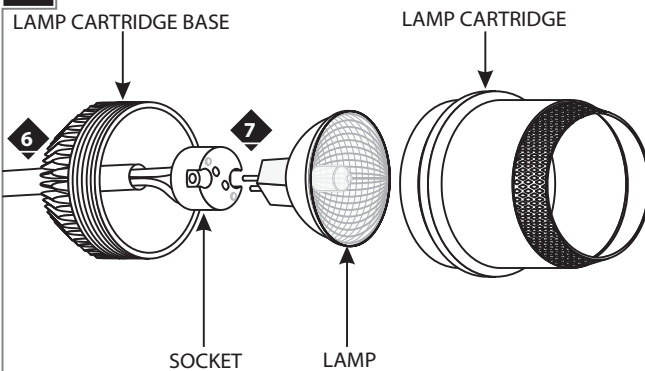

Use **MAX 50 Watt** Type MR16 Halogen Lamp.



- 5 Unscrew the lamp cartridge base from the lamp cartridge.
- 6 Pull out the socket from the lamp housing and feed it through the lamp base.
- 7 Push the lamp pins completely into the socket holes.
- 8 Place the lamp into the lamp cartridge and reinstall the lamp cartridge base and firmly tighten.

5D

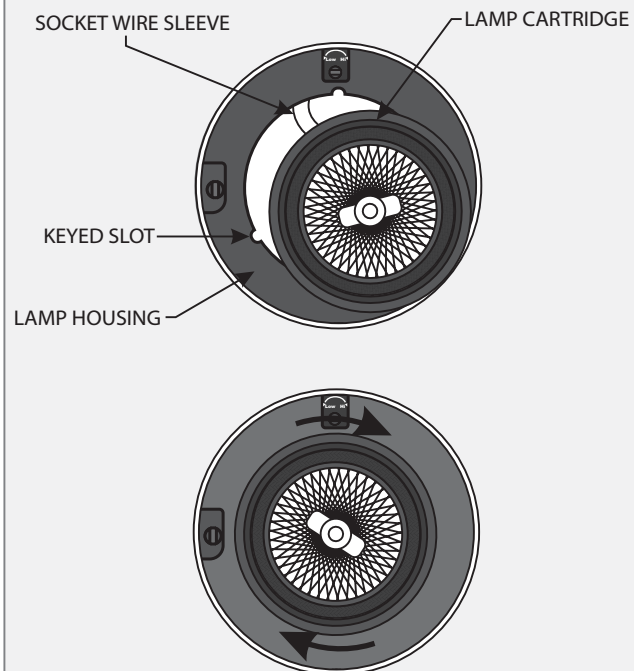

- 9 Feed the socket wire sleeve back into the lamp housing and align the lamp assembly with the keyed slots on the lamp housing.
- 10 Place the lamp assembly into the lamp housing and rotate it until it locks into place.

Adjust the Lamp Housing

NOTE: The location of the height adjustment screw is indicated with the words Low and Hi.

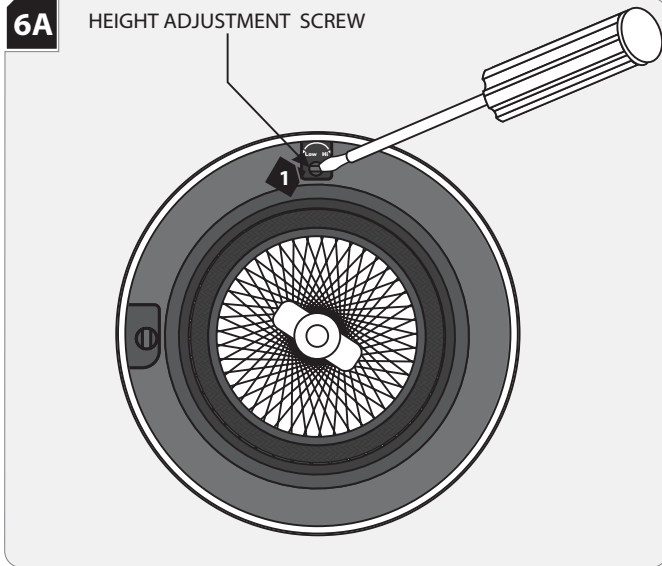

- 1 To adjust the height rotate the height adjustment screw. Adjust upward to minimize glare and flash on the trim or downward for maximum light output and efficiency.

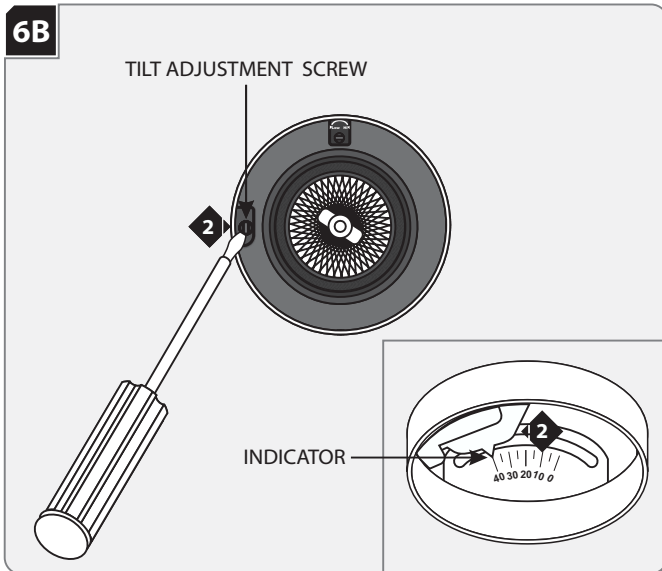

NOTE: Lamp housing can tilt 40° vertically. Lines on lamp housing are 5° apart.

- 2 To tilt the lamp housing vertically, rotate the tilt adjustment screw until the desired angle is reached.

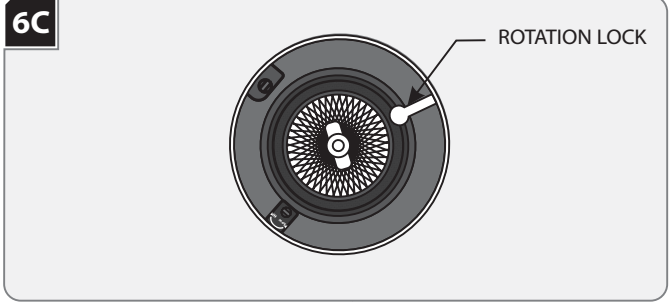

NOTE: Lamp housing can rotate 361° horizontally.

- 3 Pull the rotation lock down to unlock the lamp housing.
- 4 Rotate the lamp housing horizontally. When the desired position is achieved push the rotation lock up to lock the lamp housing in place.

SAVE THESE INSTRUCTIONS!



7400 Linder Ave, Skokie, IL 60077

847.410.4400

www.element-lighting.com

© 2014 Tech Lighting, L.L.C. All rights reserved. The "Element" graphic is a registered trademark of Element. Element reserves the right to change specifications for product improvements without notification.

A Generation Brands Company