

Installation Instructions for Merge with Emergency Battery Back-Up

ELEMENT
a brand of **TECH LIGHTING**

GENERAL PRODUCT INFORMATION:



This product is suitable for dry locations.

Maximum run length per branch circuit power feed is 80ft.

Maximum run length for low-voltage busbar is 40ft; both ends may be energized for a total of 80ft.

Maximum loading of the low-voltage busbar is 240W (20 AMPS).

This instruction shows a typical installation.

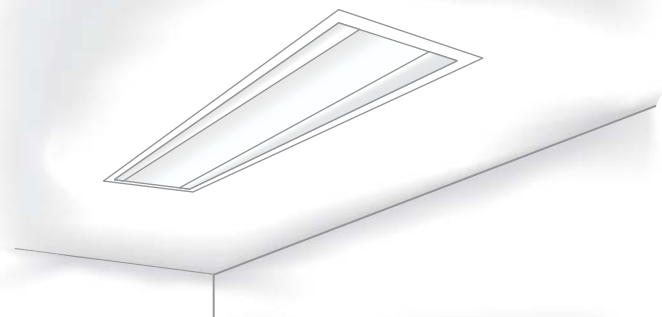

CAUTION - RISK OF FIRE

This product must be installed in accordance with the applicable installation code by a person familiar with the construction and operation of the product and the hazards involved.

Use minimum 90°C supply conductors.

MINIMUM OF 2X6 CONSTRUCTION REQUIRED.

NOTE: Due to the complexity of this fixture, assistance is recommended for installation.

Prepare for Installation

1A

MOUNTING HOLE LOCATIONS

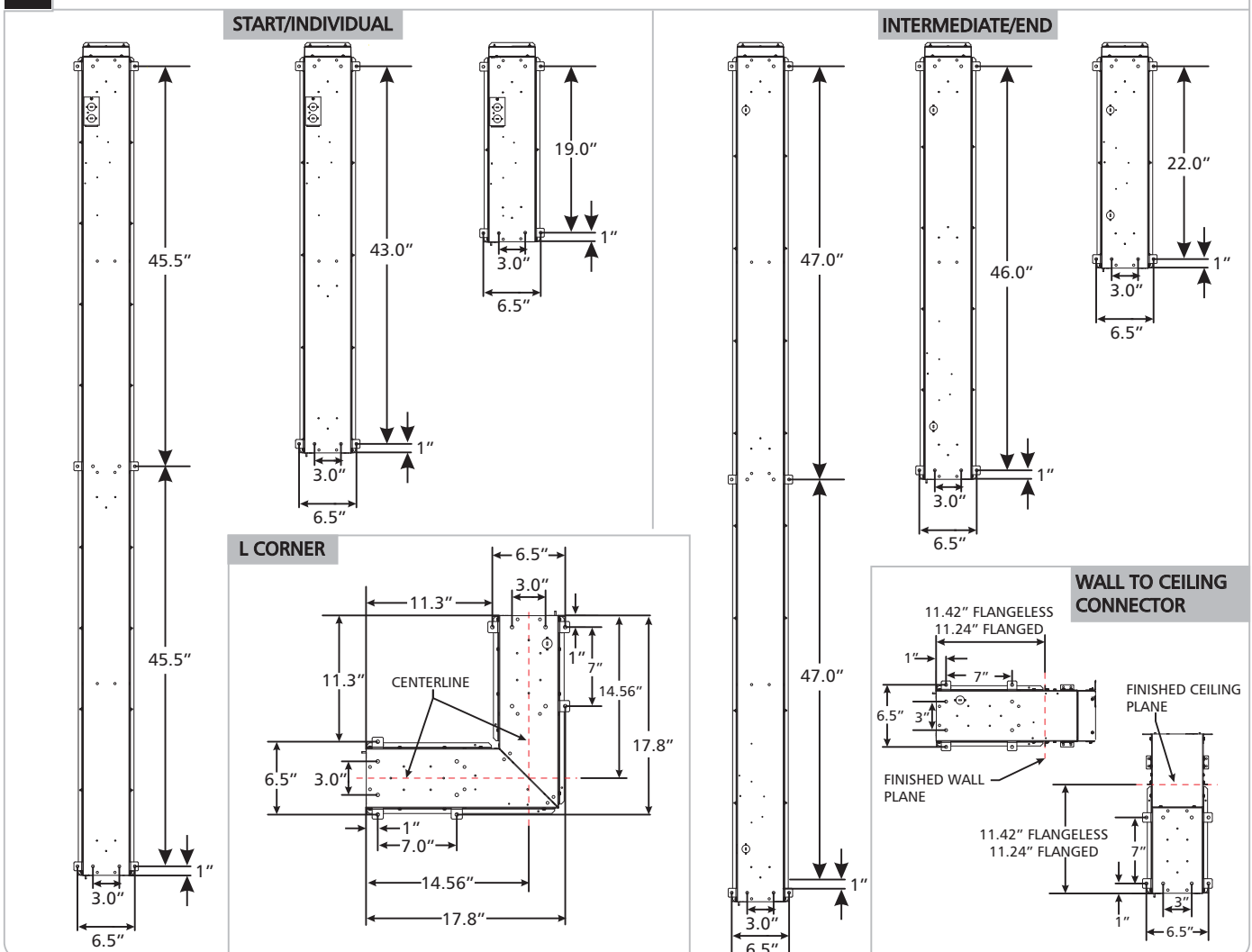

1 Install threaded rod or tie wire using the provided diagram for each model in the configuration.

Identify the Fixtures and Configuration (Continuous run installations only)

2A

There are three different elements to a Merge continuous run...

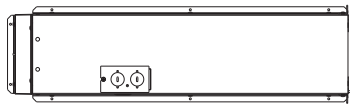

Start

The start housing will have an access plate to make line and low-voltage connections.

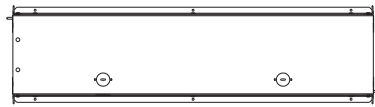

Intermediate/Connector/Transition

All housings between the start and end.

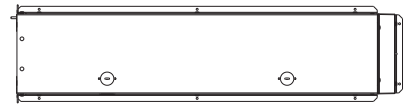

End

The end housing will have no access plate.

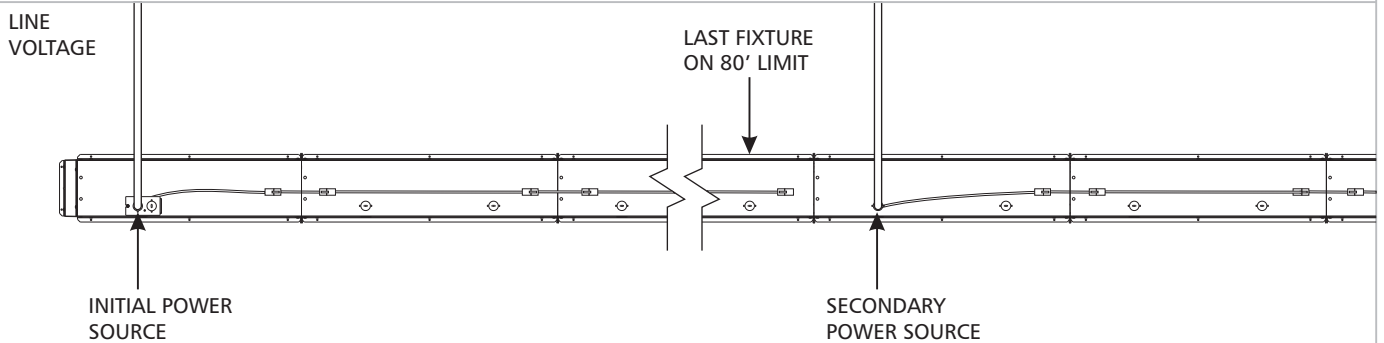

The line-voltage section of the fixture run will be powered at the start of the run, then interconnected with jumper cables to a maximum of 80'. For a longer run, sections may be isolated by simply not using a jumper. The secondary power source must be spliced to the wiring harness and connected to the fixture using one of the provided knockout locations.

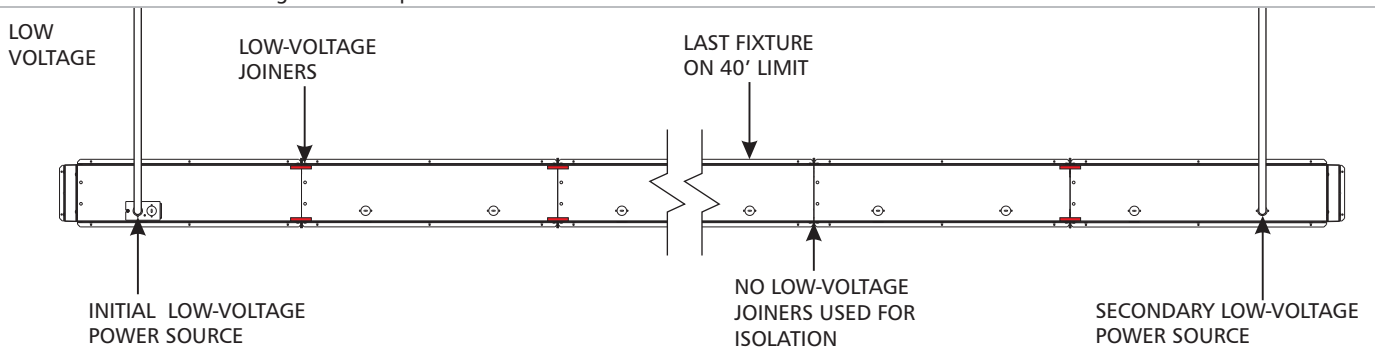

The low-voltage section of the fixture run will also be powered at the start of the run, then interconnected with low-voltage joiners to a maximum of 40'. Sections of the run may be isolated by simply not installing the low-voltage joiners and the run may be powered by multiple transformers at different ends to power longer runs.

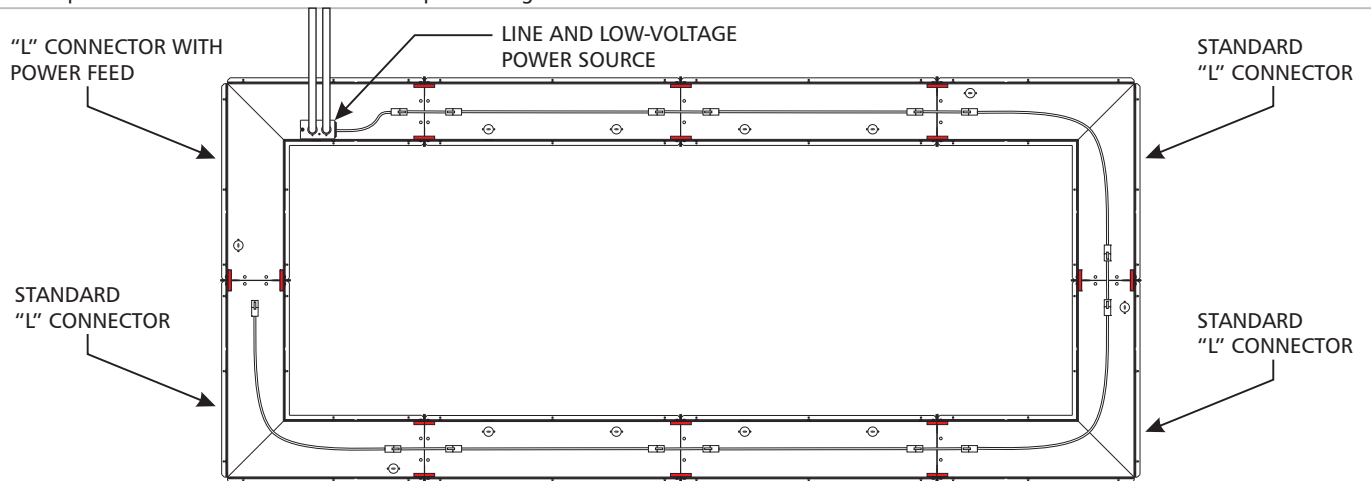

When using "L" Connectors as a start fixture of a run or in an enclosed run, at least one "L" Connector with Power Feed must be used within the run. The "L" Connector with Power Feed must not be used as an intermediate/connecting fixture as it does not have internal low-voltage connections like the standard "L" Connector; for enclosed runs under 80', all other "L" Connectors must be standard. If a run exceeds the 80' line-voltage and 40' low-voltage limit, secondary low and line-voltage power sources must be used following the instructions illustrated above.

INSTALLATION OPTIONS:

For Flangeless install - see section 3

For Flanged install - see section 4

For Grid install - see section 5

Install Each Fixture (Flangeless)

3A

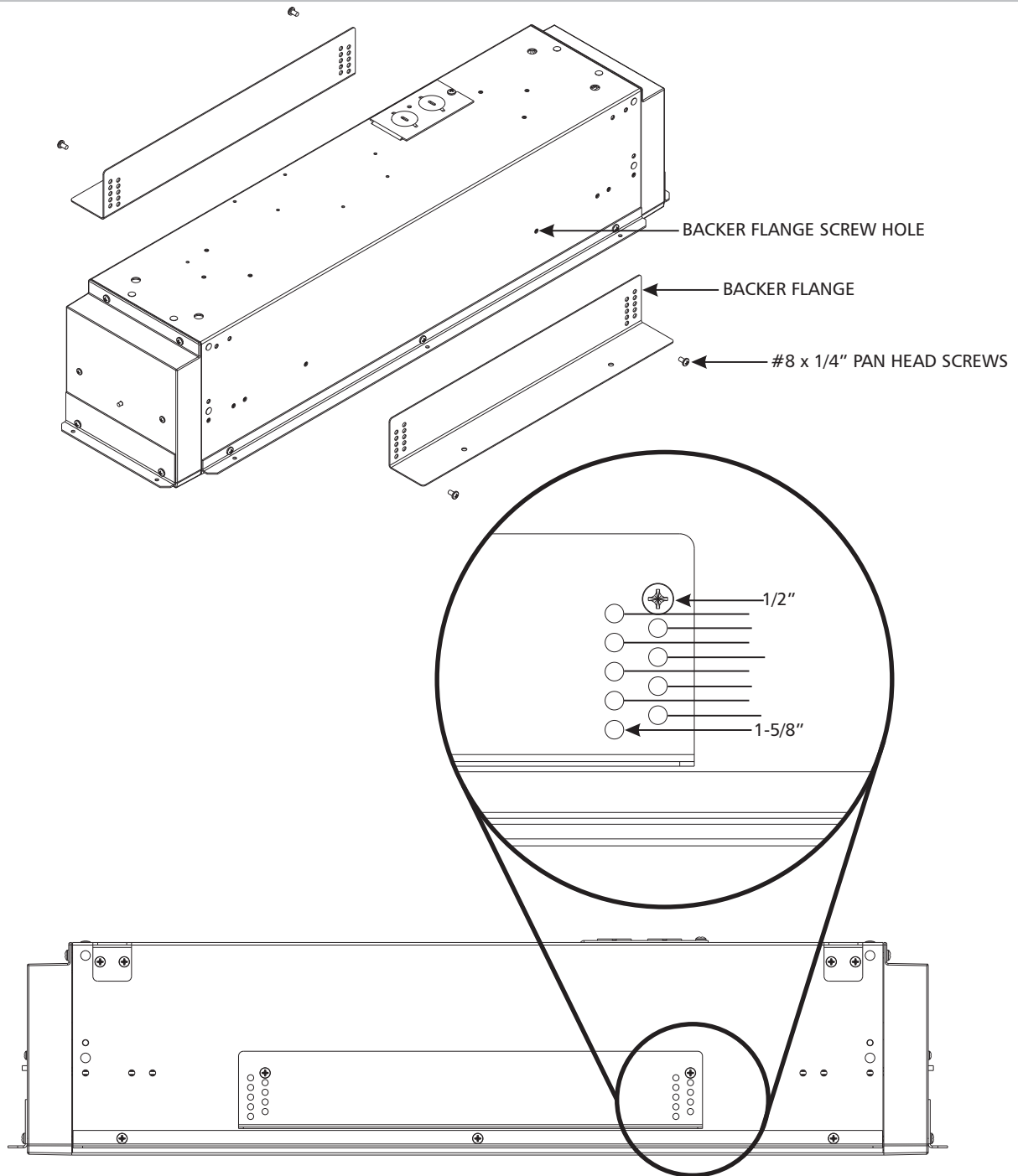

- 1 Set the height of the backer flange according to the finished ceiling thickness (maximum 1-5/8" ceiling thickness): install the flange at the appropriate height using the #8 x 1/4" pan head screws. The holes are spaced 1/8" apart.

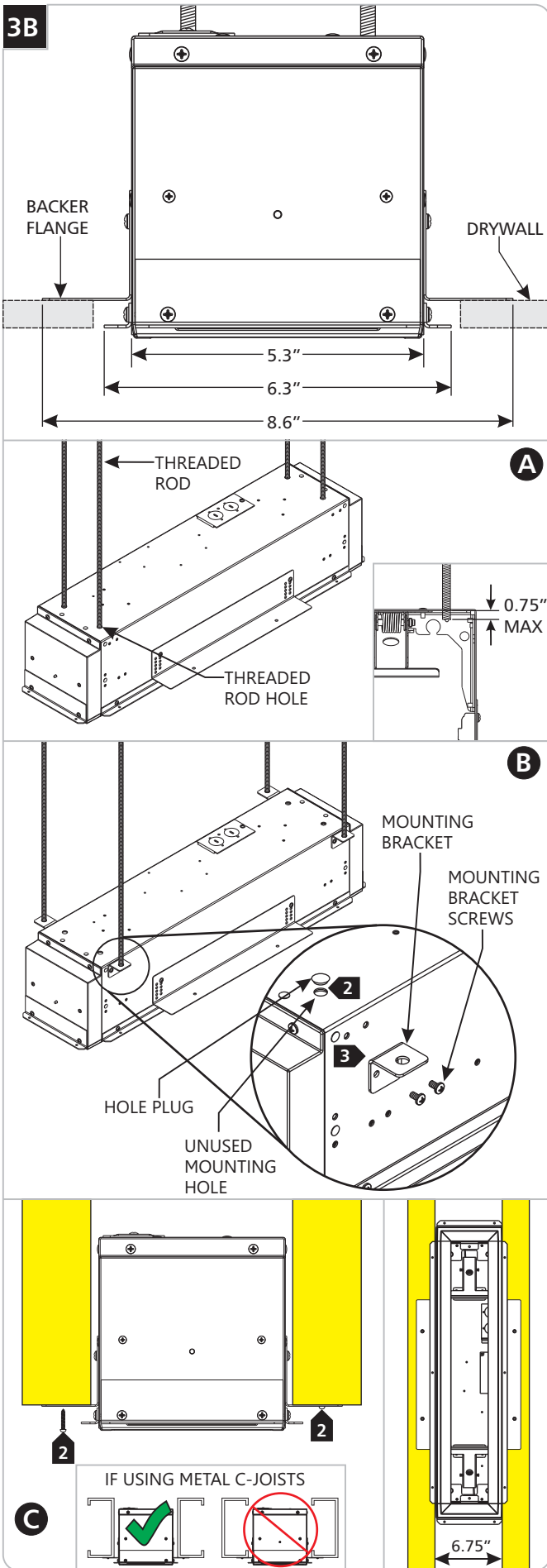

Install the fixture(s) so that the backer flange is aligned with the drywall plane using one of the following options. If installing a continuous run, see section 6 for assembly details once an installation method has been determined:

NOTE: If installing a continuous run, see section 6 for details before installation.

If not installing a continuous run, skip to section 7 once installation is complete.

A This option uses 1/4" threaded rod to support the fixture(s) internally. **Note:** Recommended for flanged versions: this option will give the opportunity to snug the fixture up to the ceiling after the drywall has been installed.

1 Use the holes to properly support the fixture using threaded rod or tie wire in accordance with local code. Threaded rod must not protrude more than 0.75" into the fixture housing.

B This option uses threaded rod or tie wire to support the fixture(s) externally. **Note:** this option may not allow easy adjustment to the fixture's height after the drywall has been installed.

1 Install two mounting brackets to each end of the fixture using the provided bracket screws (8' models require two brackets in the center of the fixture as well).

2 Install the provided hole plugs into all the unused mounting holes.

3 Use the brackets to properly support the fixture using threaded rod or tie wire in accordance with local code.

C This option uses framing to install the fixture(s) (suggested for wall installation).

1 Install the framing to create 6.75" of clearance needed for the fixture.

2 Using wood screws, secure the fixture into the joists by screwing through the backer flanges.

Install Each Fixture (Flanged)

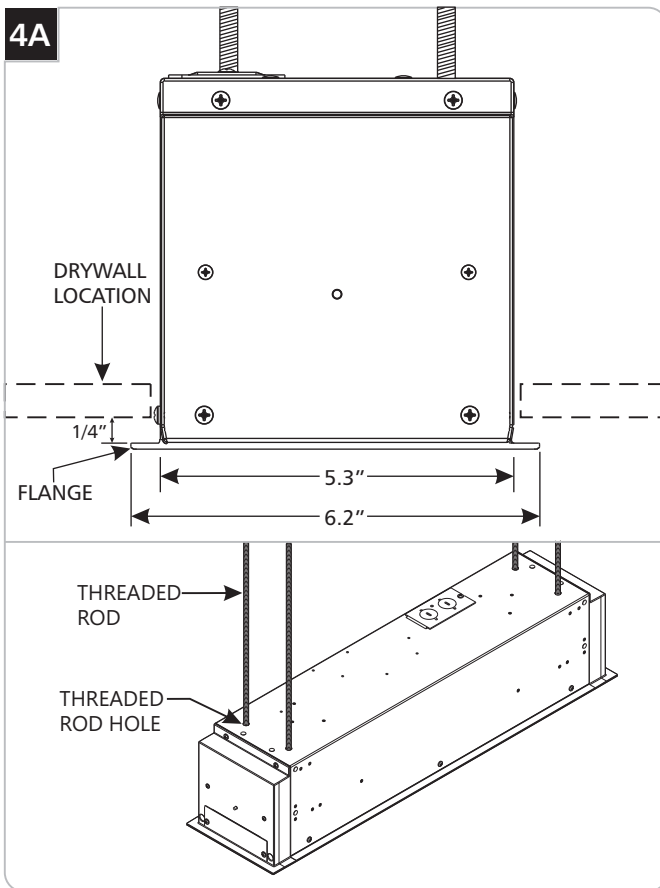

NOTE: If installing a continuous run, see section 6 for details before installation.

If not installing a continuous run, skip to section 7 once installation is complete.

- 1 Use the holes to properly support the fixture using threaded rod in accordance with local code. Install the fixture(s) 1/4" lower than the drywall ceiling plane.

Install Each Fixture (Grid)

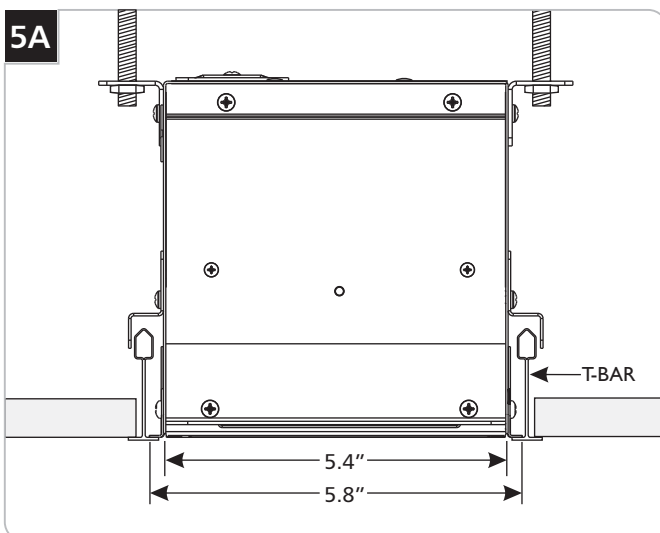

- 1 Build a 6" on center grid to accommodate the fixture(s) (see next diagram).

Install Each Fixture (Grid)

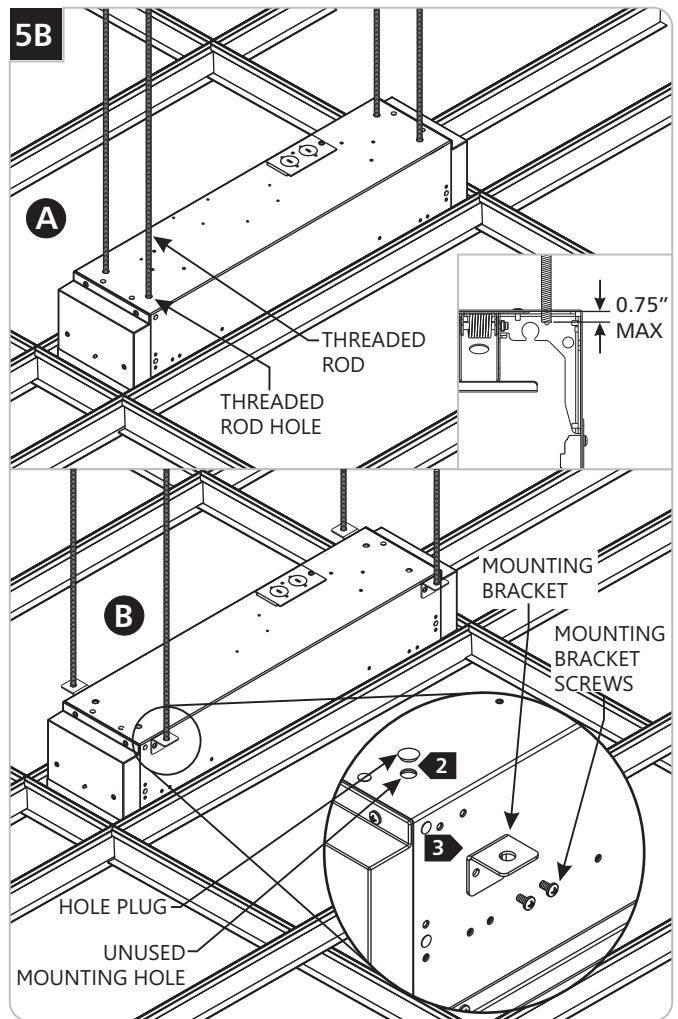

Choose one of the following installation options. If installing a continuous run, see section 6 for assembly details once an installation method has been determined. If not installing a continuous run, skip to section 7 once installation is complete:

- A Use 1/4" threaded rod to support the fixture(s) internally.
 - 2 Use the holes to properly support the fixture using threaded rod or tie wire in accordance with local code. Threaded rod must not protrude more than 0.75" into the fixture housing.
- B Use threaded rod or tie wire to support the fixture(s) externally.
 - 2 Install two mounting brackets to each end of the fixture using the provided bracket screws (8' models require two brackets in the center of the fixture as well).
 - 3 Install the provided hole plugs into all the unused mounting holes.
 - 4 Use the brackets to properly support the fixture using threaded rod or tie wire in accordance with local code.

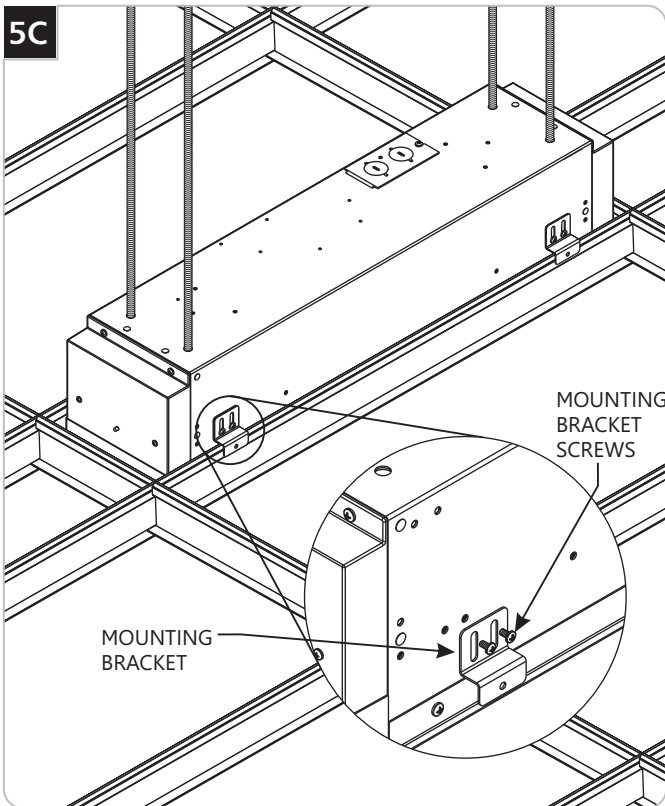
5C

- 5** Install two grid mounting brackets to each end of the fixture using the provided bracket screws (8' models require two brackets in the center of the fixture as well).

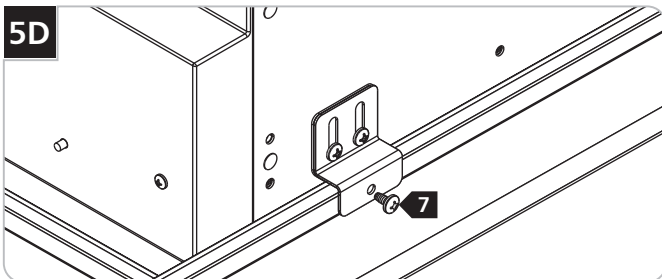
5D

- 6** To further secure the fixture or per local code, use the screws slots on the sides of the brackets to secure the fixture to the T-bar.

Installing a Continuous Fixture Run

NOTE: If installing a continuous wall to ceiling connector, start the continuous fixture run installation with the connector.

If not installing a wall to ceiling connector, skip to the next step.

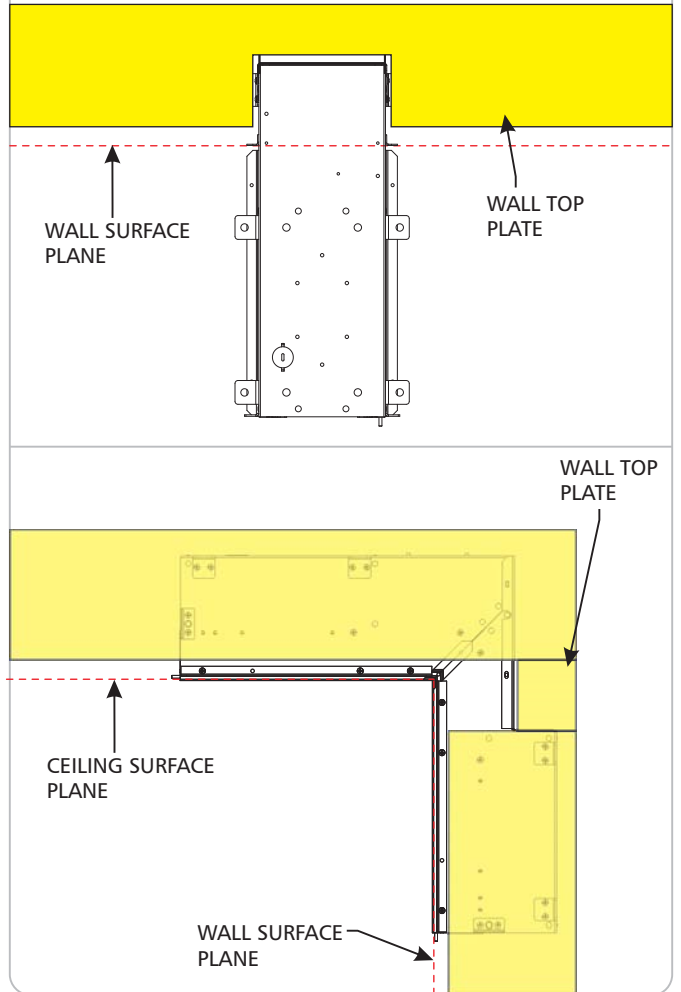
6A

- 1** To create clearance for the ceiling to wall connector, the wall top plate must be modified, following guidelines in accordance with local building code, to accommodate the fixture's depth. Use section 3 to install the wall to ceiling connector.

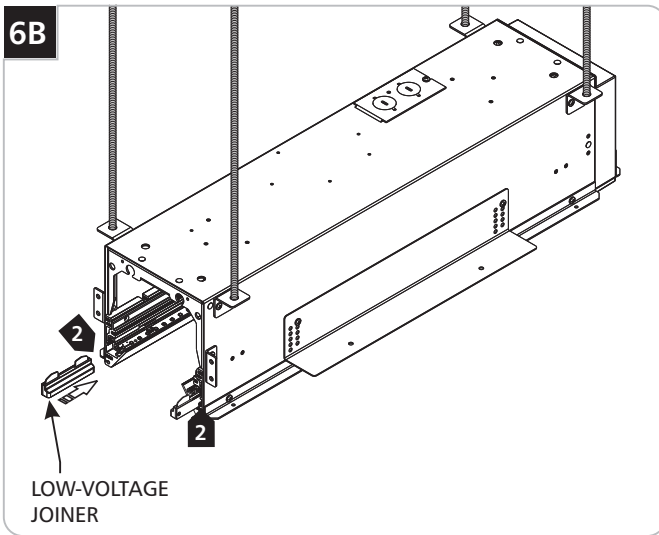

2 If utilizing the low-voltage feature, install low-voltage joiners into each side of the first fixture.

3 Install the first fixture using one of the methods described in the previous related section.

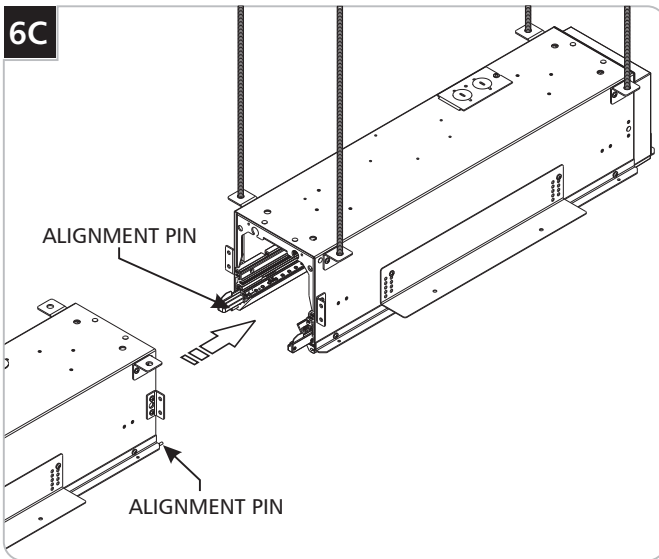

4 Using the alignment pins as a guide, slide the next fixture against the already installed fixture and secure the fixture in place using the preferred mounting method.

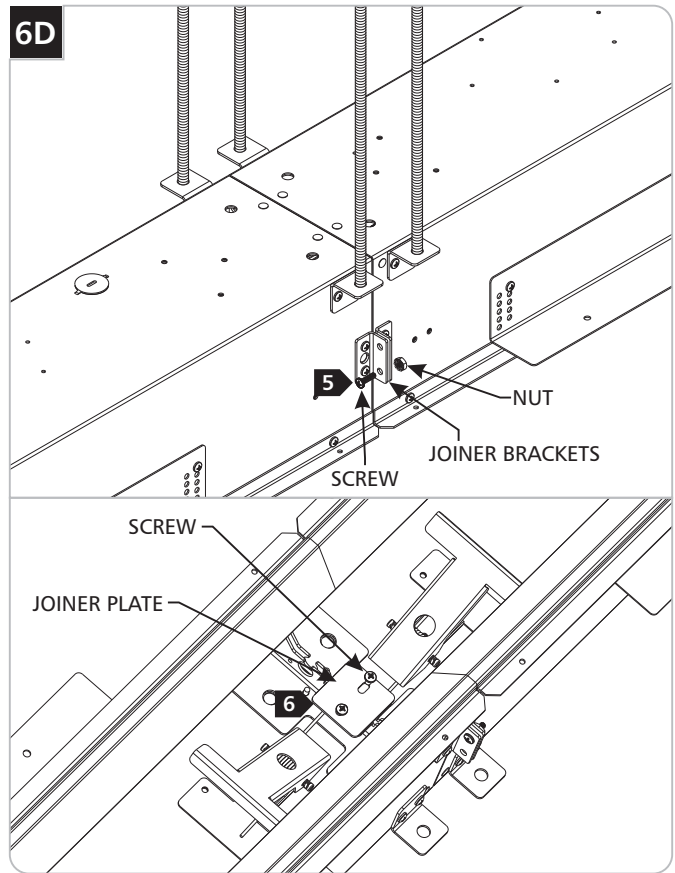

5 With the provided screws and nuts, join the fixture housings together by the joiner brackets on each side, take care to not over-tighten (if using the framing method, skip this step).

6 Also install the joiner plate inside the fixture with the provided screws.

7 Repeat steps 2-6 for the following fixture(s).

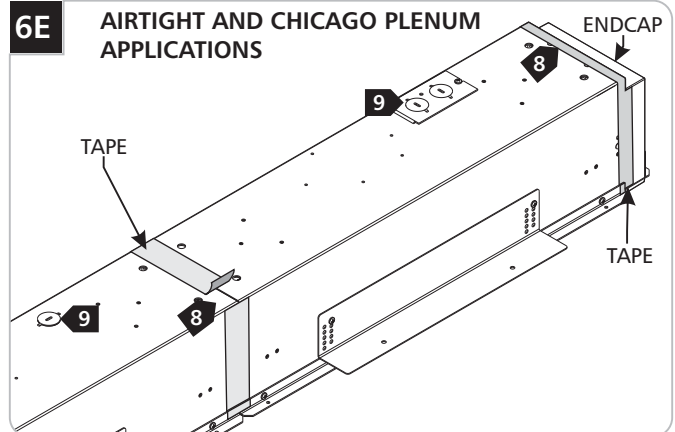

8 For airtight and Chicago plenum applications, use the tape provided to seal the seams between the fixtures and at the endcaps.

9 Tape any unused knockouts and the conduit fittings.

10 Tape the opening in the endcaps, if present.

11 Use the screws provided to fill in any unused holes.

Wire the Fixture

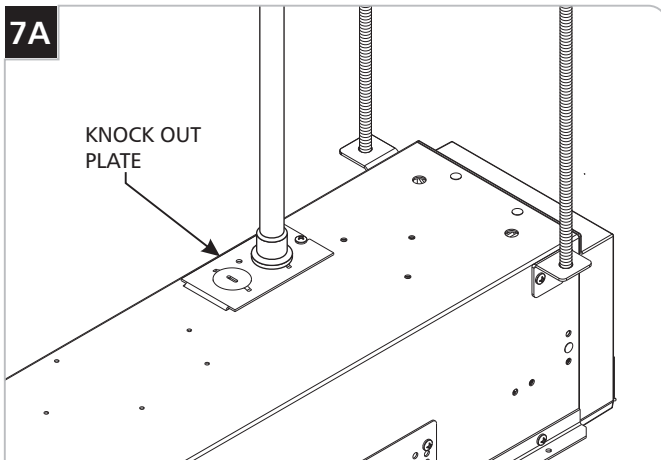

- 1 Install conduit to the fixture knock out plate.
- 2 Run the power line wires into the fixture electrical box.
- 3 If utilizing the low-voltage feature, use the remote transformer's instruction to install and wire the transformer, then run the low-voltage power lines to the fixture.
- 4 Power the fixture using the following wire diagrams according to the driver included with the fixture.

NOTE FOR CONTINUOUS FIXTURE RUNS: if connecting power anywhere other than the start of the run: splice the power and control wires in the fixture cord and properly connect the color coded wires with wire nuts.

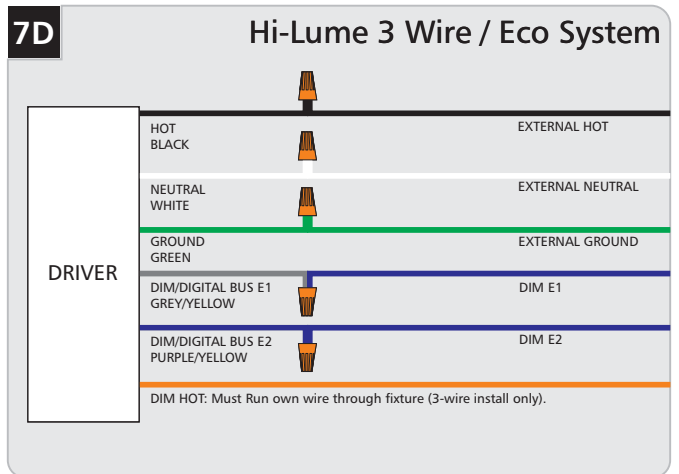
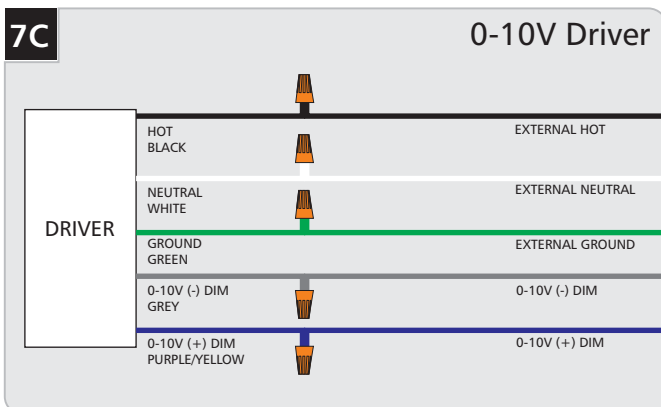
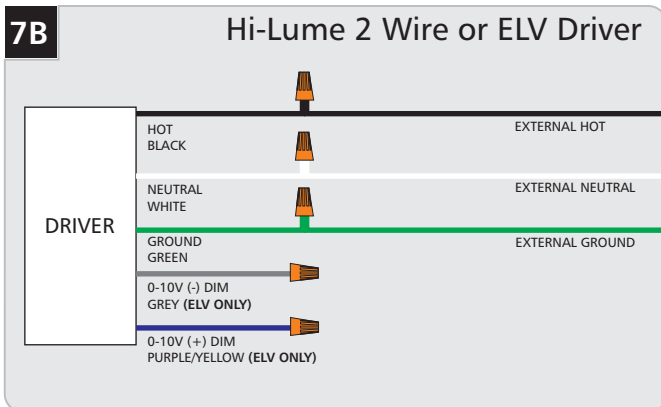

NOTE: an additional un-switched external hot line will also be required for the emergency backup system as shown in diagram below.

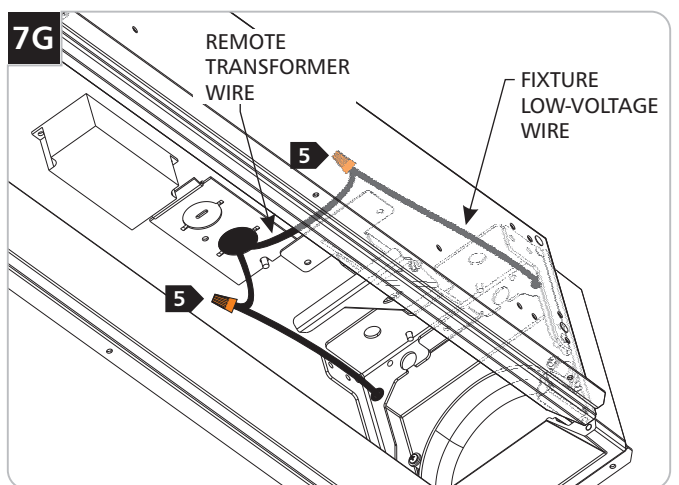
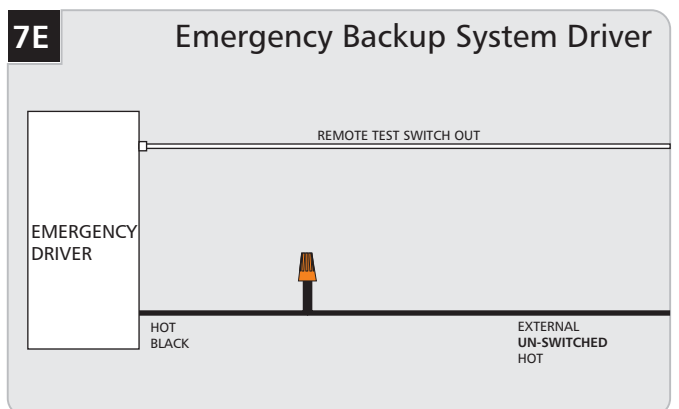

- 5 Connect the fixture's low-voltage wires to the remote transformers low-voltage power lines.
- 6 If installing an individual fixture and wiring is complete, install the dust covers provided to protect the electronics.

NOTE: The remainder of this section is for continuous fixture runs. If installing an individual fixture, skip to section 8 for flangeless installs or to section 9 for flanged installs.

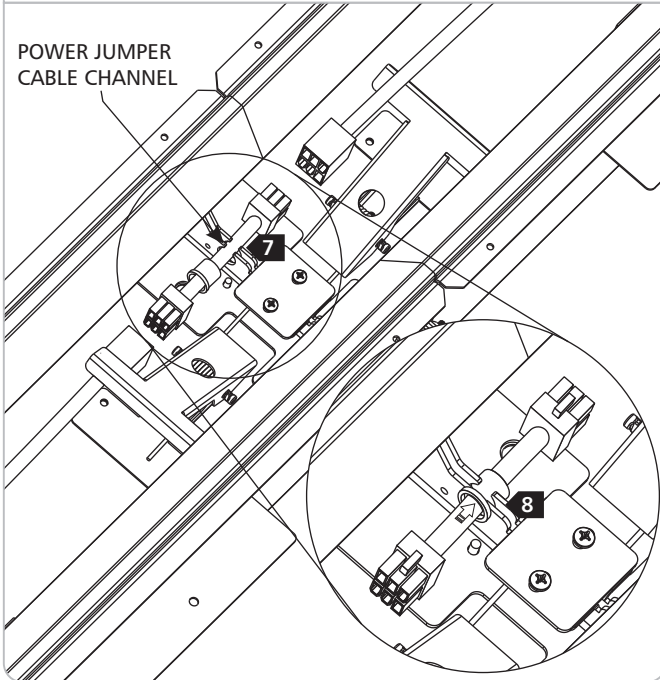
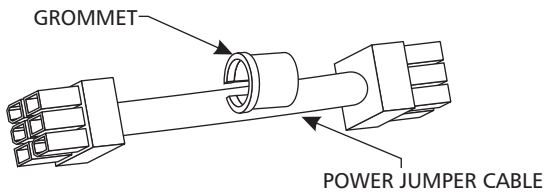
7H

7 Insert the grommet onto the power jumper cable.

8 Insert the cable into the channel between the fixtures and slide the grommet in to lock it in place.

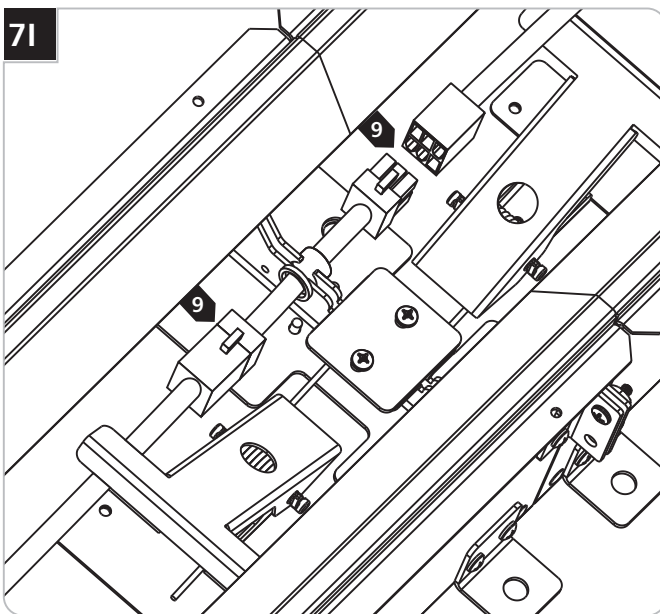
7I

9 Use the jumpers to connect the fixture power cables together.

10 After wiring inside the fixture is complete, install the dust covers provided to protect the electronics.

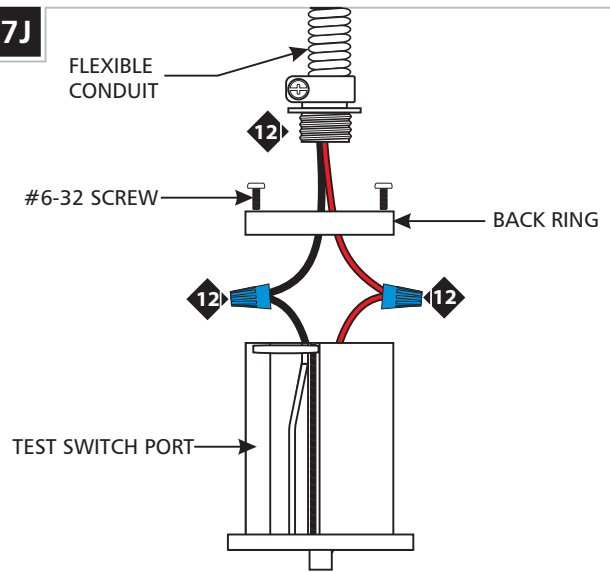
7J

11 Unscrew the #6-32 screws to open the test switch port.

12 Disconnect the wires.

13 Unscrew the back ring from the flexible conduit.

14 Replace the back ring onto the port so the end of the wing screws are properly placed in the two blind holes.

15 Replace and tighten the #6-32 screws to secure the back ring onto the test switch port.

16 Keep the test switch port assembly in a safe place while the drywall is being installed.

INSTALL THE DRYWALL

Flangeless - Go to Section 8

Flanged - Go to Section 9

Install the Drywall (flangeless)

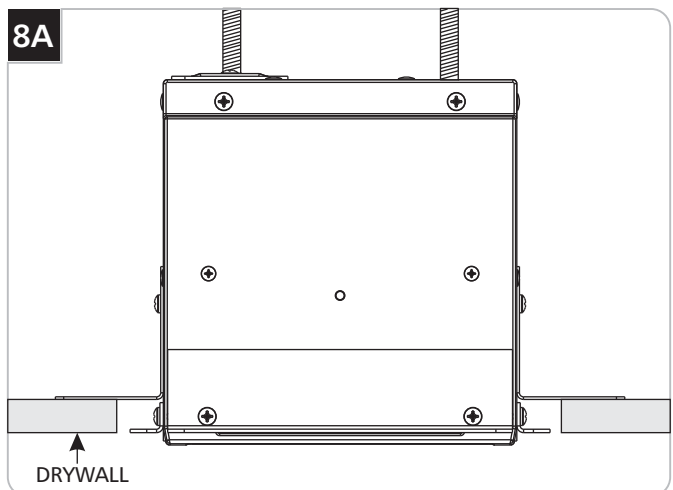
8A

1 Install drywall up to the fixture housing(s).

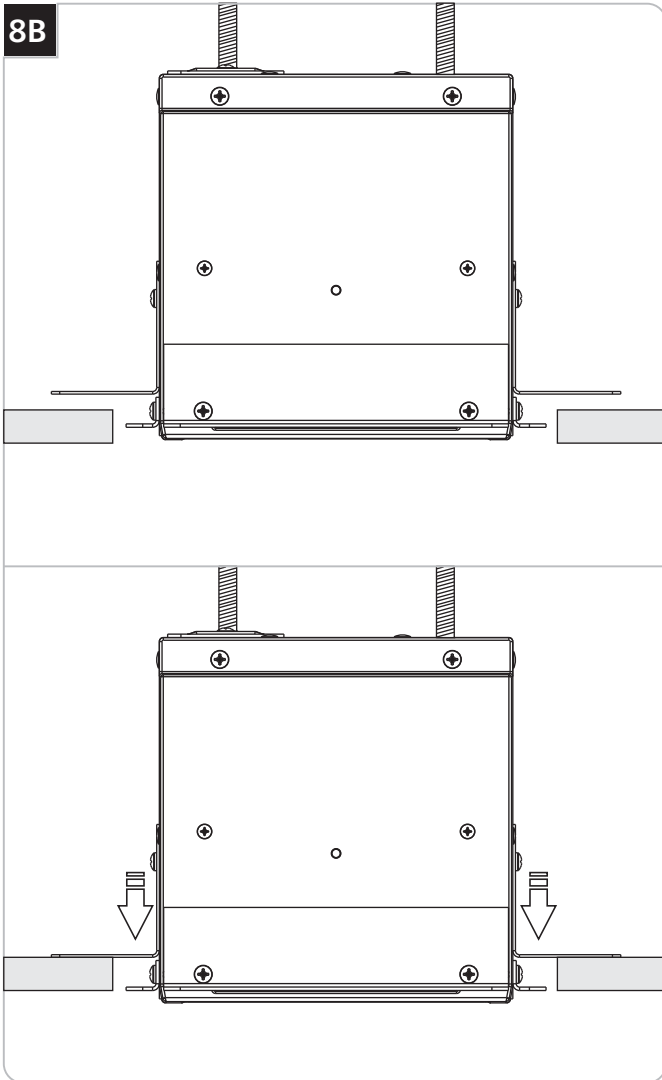

2 If necessary, adjust the fixtures height so that the backer flange makes contact to drywall surface .

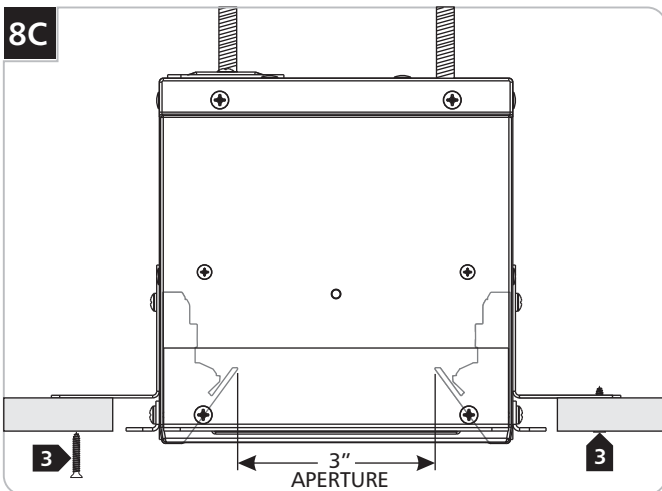

3 Secure the drywall to the backer flange by either drilling a pilot hole and screwing in sheet metal screws or use self-drilling sheet metal screws.

WARNING: Fixture aperture width should not be less than 3". If the fixture is compressed during installation, the reflector will be difficult to install.

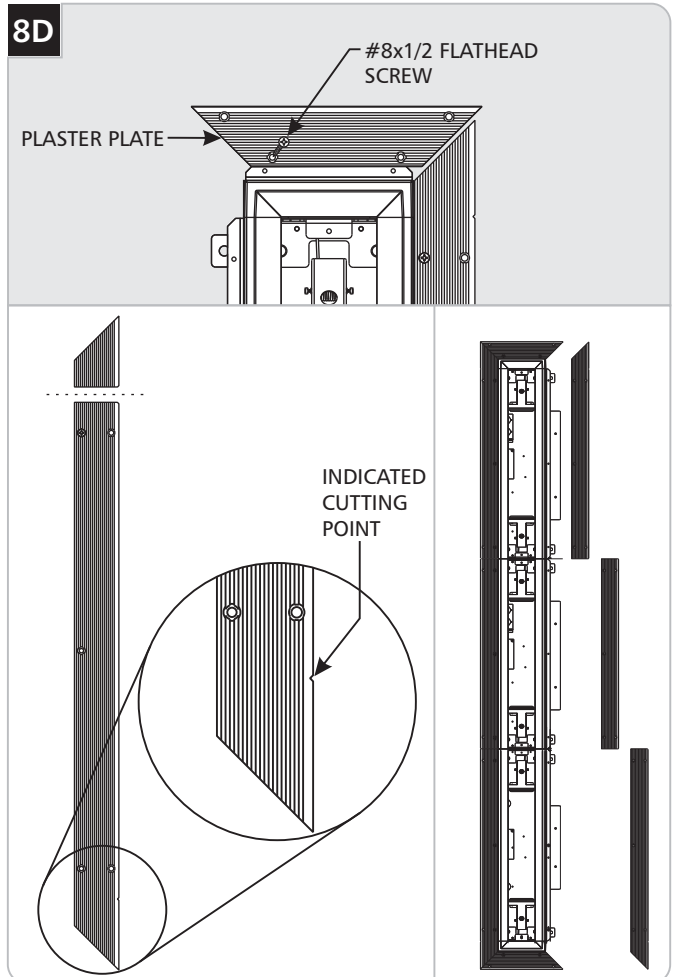

4 Secure the plaster plates to fixture(s) using the supplied #8x1/2 flat head screws:

Start with the ends to use the mitered pieces.

For intermediate sections, evenly trim the mitered ends off the long plaster plates at the indicated cutting point.

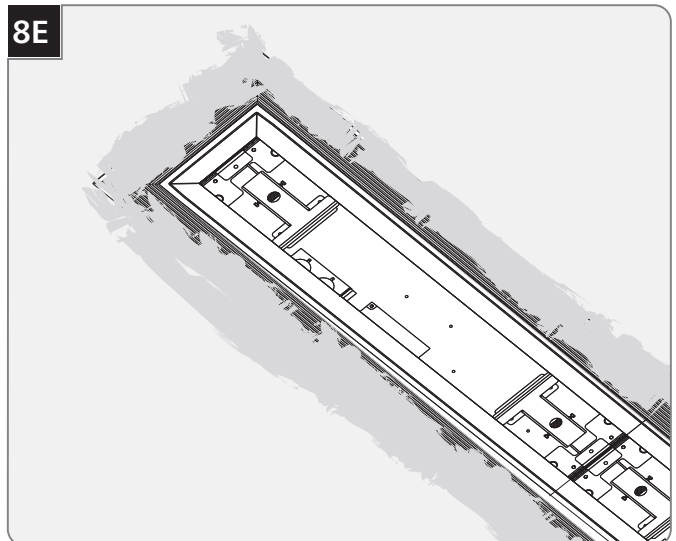

5 Properly plaster onto the plaster flange and drywall.

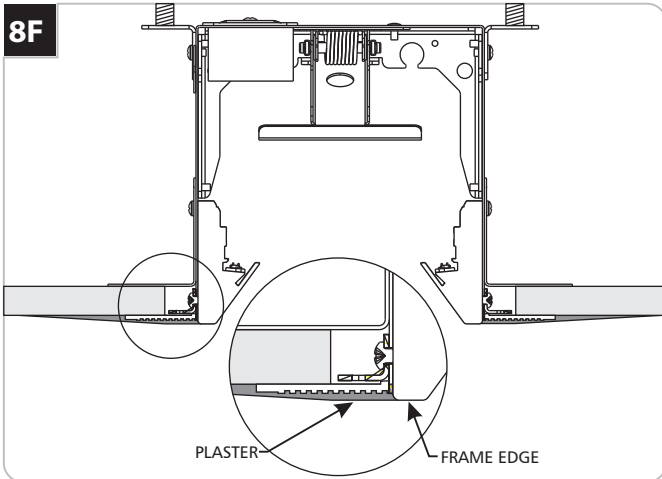

6 Plaster up to the frame edge for a seamless appearance.

7 **Warning!** Move on to section 10 before painting the drywall and fixture bevel.

Install the Drywall (flanged)

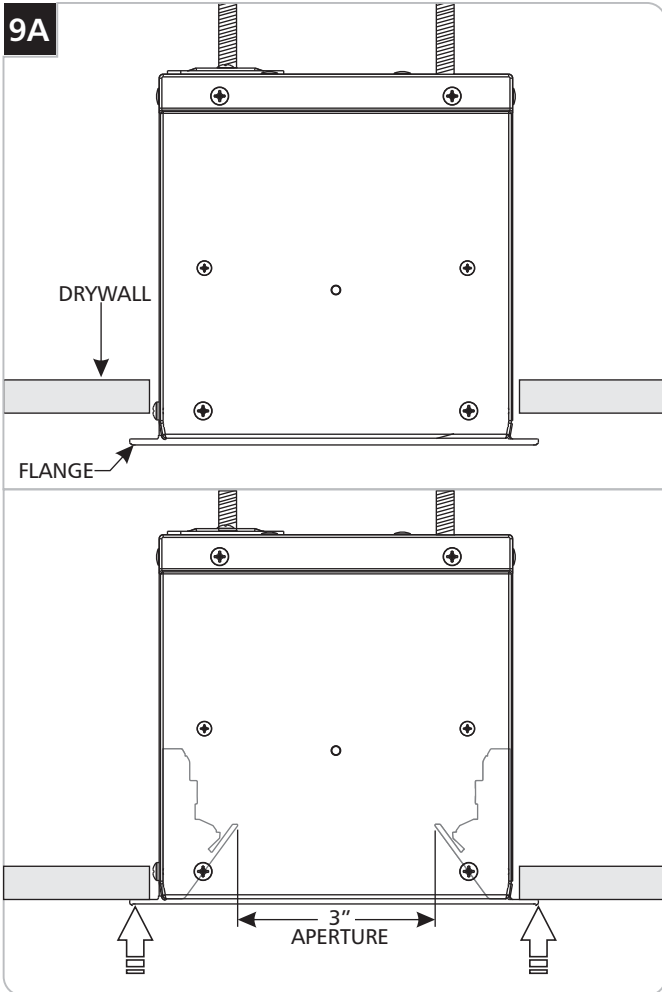

1 Install drywall up to the fixture housing(s).

2 Adjust the fixtures height so that the fixture flange is just snug to the drywall surface. **DO NOT OVER TIGHTEN.**

WARNING: Fixture aperture width should not be less than 3". If the fixture is compressed during installation, the reflector will be difficult to install.

Painting the Bevel (optional)

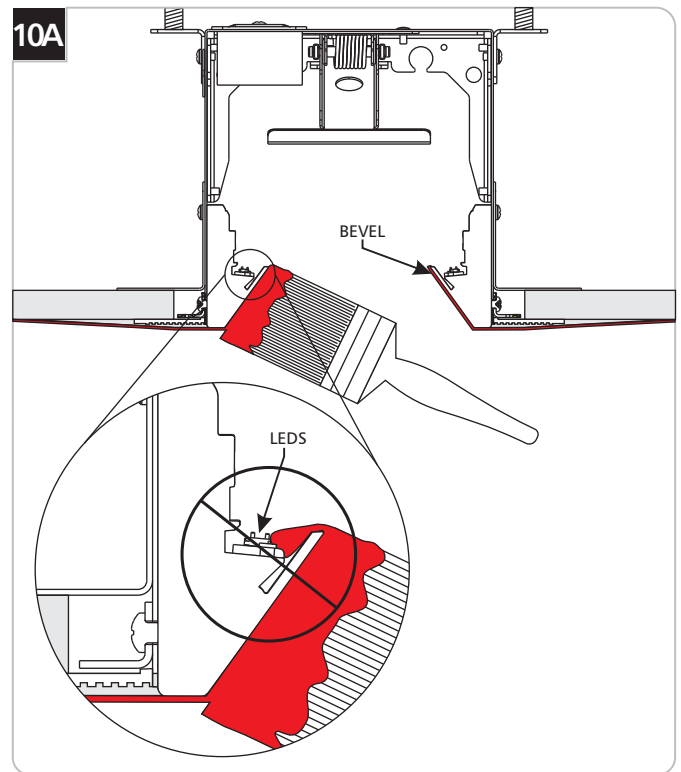

1 The fixture bevel may be painted to match the ceiling color. **Take caution not to over paint!** This will result in damaging the LEDs.

Install Remote Test Switch

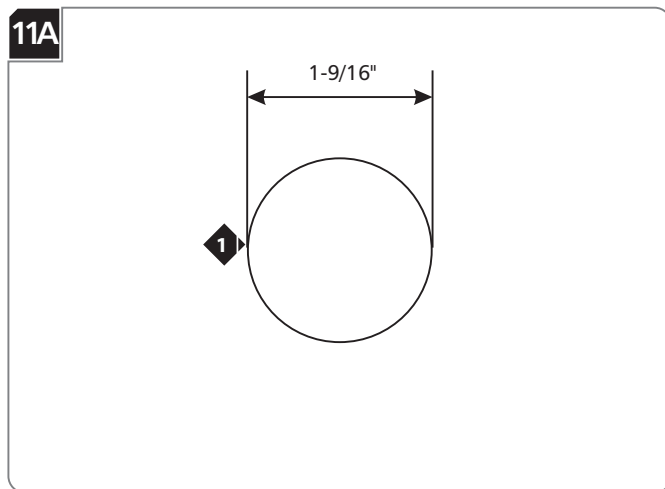

- 1 Use a 1-9/16" hole saw to cut out the ceiling or wall where the test switch will be installed.

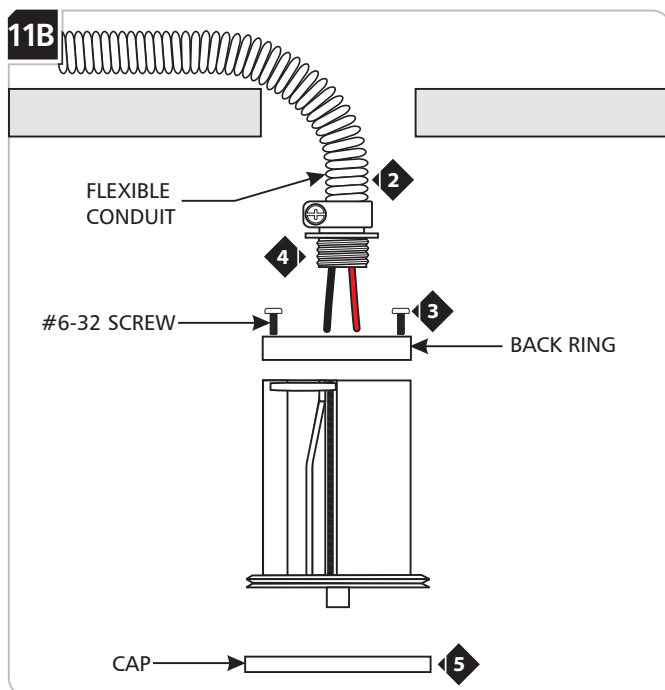

- 2 Bring the flexible conduit out of the 1-9/16" hole.
- 3 Unscrew the #6-32 screws and remove the back ring.
- 4 Screw the back ring (from the face with two holes) to the flexible conduit.
- 5 Unscrew the cap from the test switch port.

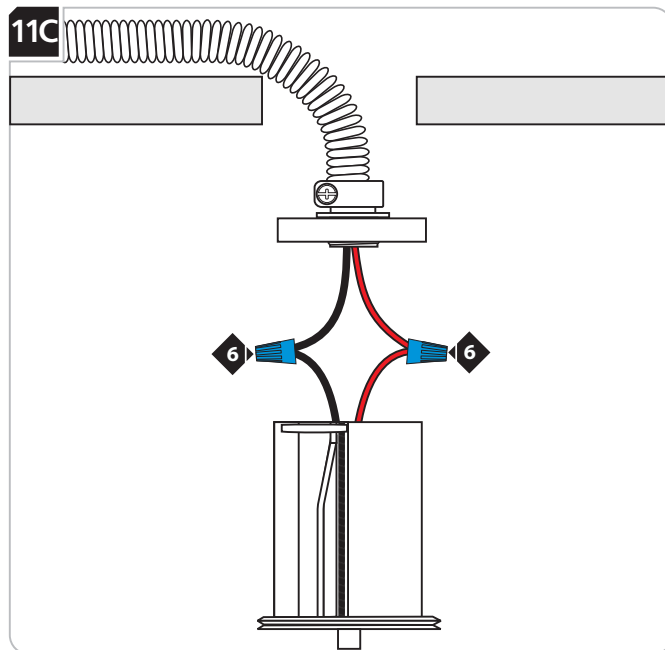

- 6 Connect the red and black wires in the test switch port to the same color wire in the flexible conduit using wire nuts.

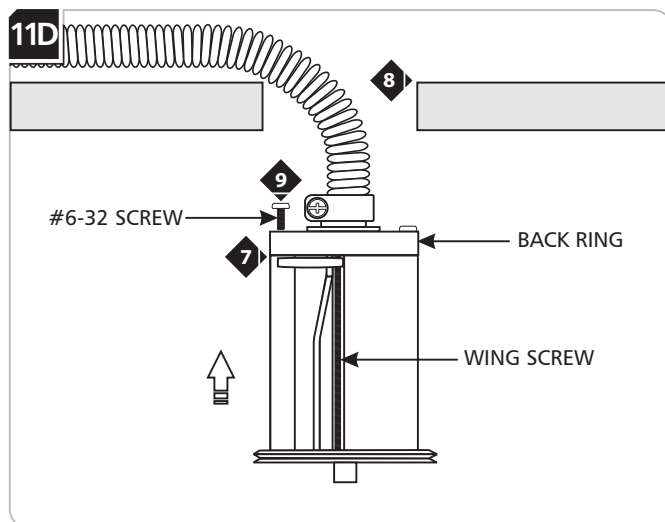

- 7 Replace the back ring onto the test switch port so the end of the wing screws are properly placed in the two blind holes.
- 8 Replace and tighten the #6-32 set screws to secure the back ring onto the test switch port.
- 9 Push the test switch port completely into the hole.

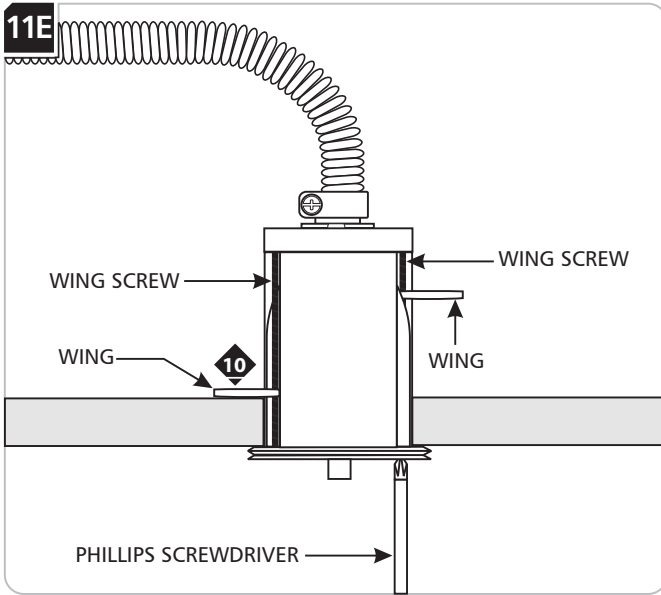

- 10 Tighten the two phillips screws (an electric screwdriver will help) until the wings secure the test switch port into the hole.

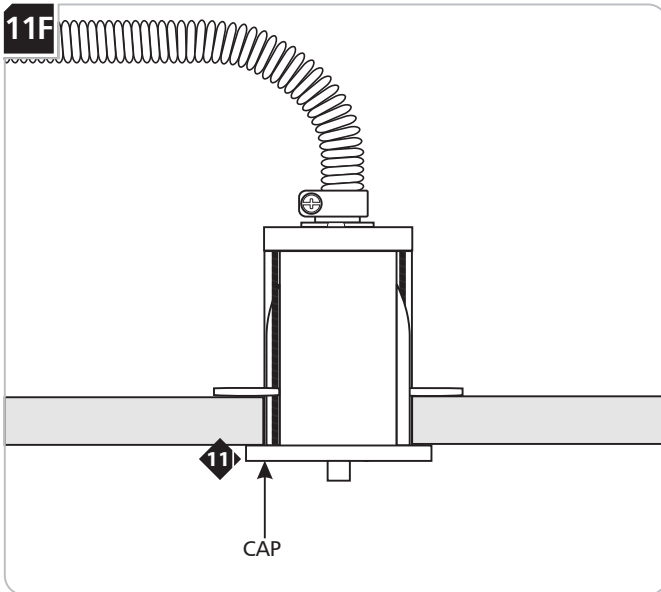

- 11 Replace and tighten the cap.

Install the Reflector

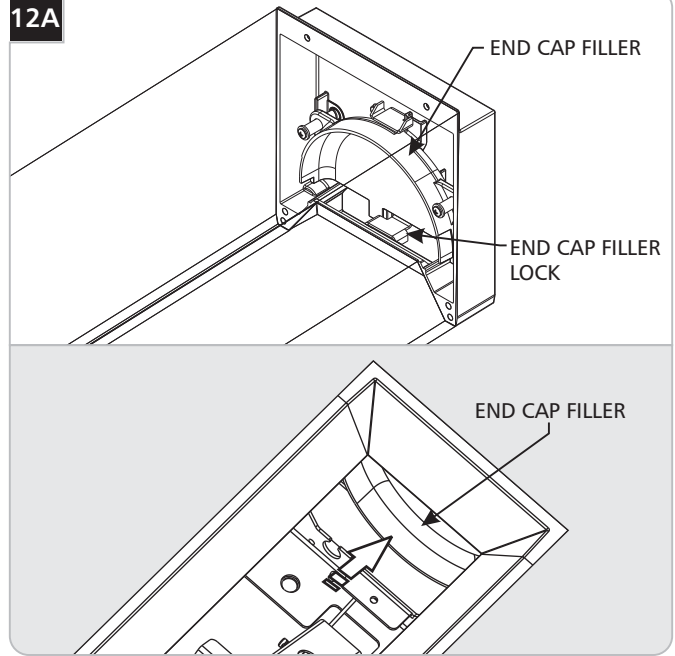

- 1 Make sure that the end cap filler is in the compressed position. If it is not, compress the end cap filler in and lock it in place.
- 2 Remove the cross braces.

12B

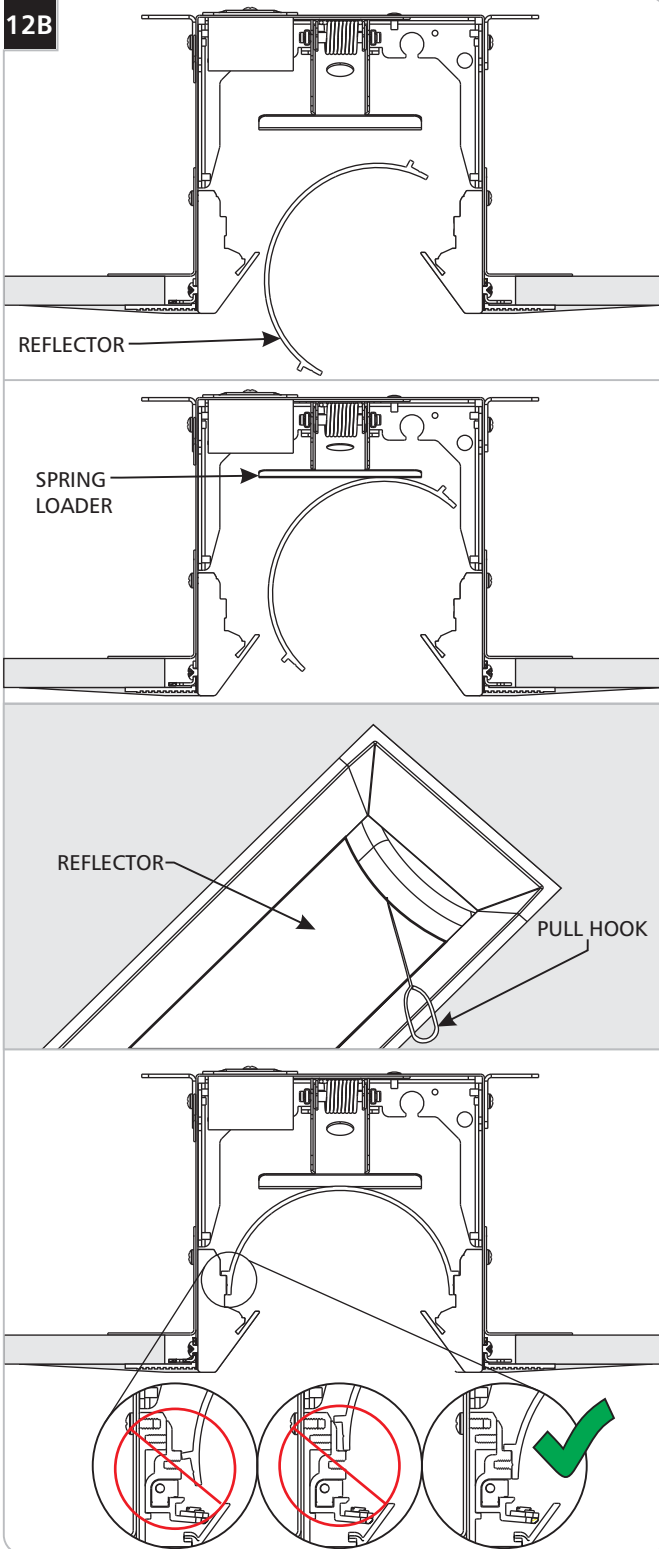

NOTE: If your fixture run consists of corner connectors, the corner reflectors should be installed prior to the linear reflectors.

- 2 Install the reflector by first tilting in and inserting it into the fixture.
- 3 Tilt the reflector back to position, some resistance will be felt by the spring loader, and rest it evenly inside the fixture. If necessary, use the included pull hook to set the reflector in position. Repeat for all reflectors for multiple runs.
- 4 Ensure that the reflector is resting in the correct position.

12C

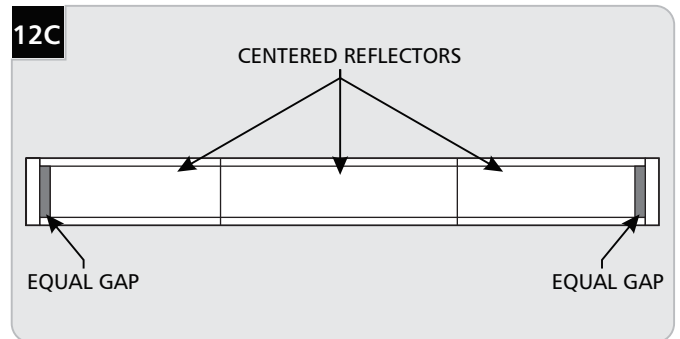

- 5 Slide the reflector(s) towards the center of the fixture/run so that there are equal gaps on each end.

12D

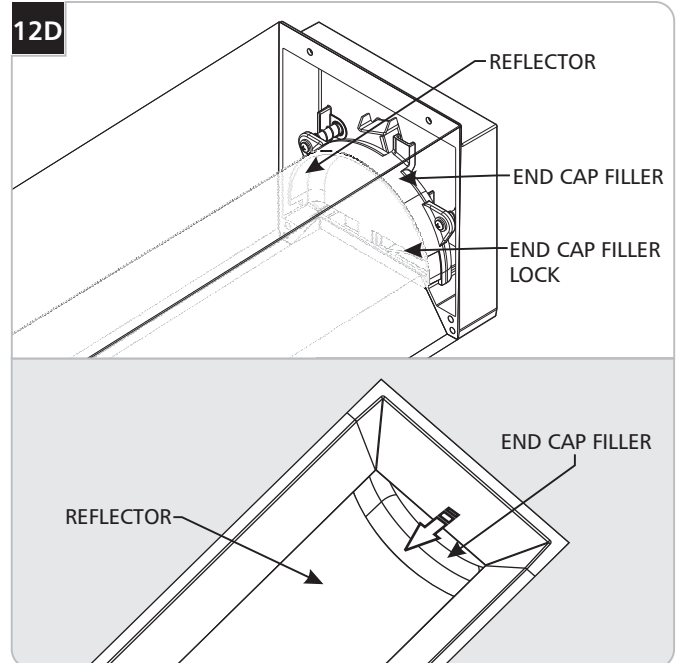

- 6 Unlock the end cap filler and ensure that it is flush with the reflector.

NOTES:

ELEMENT
a brand of **TECH LIGHTING**

7400 Linder Ave.
Skokie, IL 60077
847.410.4400

www.element-lighting.com

© 2015 Tech Lighting, L.L.C. All rights reserved. The "Element" graphic is a registered trademark of Element. Element reserves the right to change specifications for product improvements without notification.