

Round or Square Type Downlight Shallow Housing with Halogen Lamp

E3_-HDS_ 1.0

TECH LIGHTING®

ELEMENT

GENERAL PRODUCT INFORMATION:



Versions with a toroidal transformer may be dimmed with a low-voltage magnetic dimmer.

Versions with an electronic transformer may be dimmed with a standard electronic dimmer.

This instruction shows a typical installation.

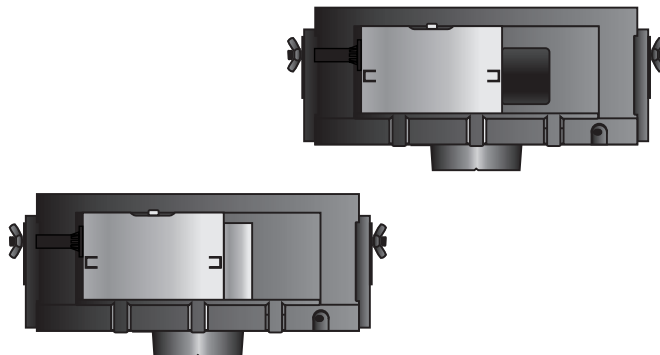

CAUTION - RISK OF FIRE
 This product must be installed in accordance with the applicable installation code by a person familiar with the construction and operation of the product and the hazards involved.
 Use minimum 90°C supply conductors.

SAVE THESE INSTRUCTIONS!

Install the Housing with Adjustable Bars

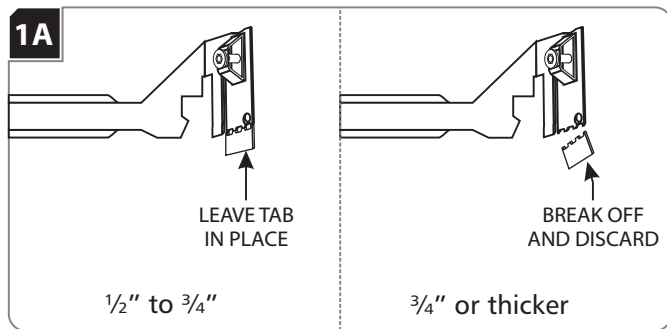

NOTE: Skip this section if installing the housing with butterfly brackets.

- 1 **Keep Tab for ceiling 1/2" to 3/4" thick.**
 When using adjustable hanger bars with 1/2" to 3/4" thick ceilings, leave the tab of the hanger bars in place.
Break off Tab for ceiling 3/4" or thicker.
 When using adjustable hanger bars with 3/4" or thicker ceilings, remove the tab by bending it at the perforation.

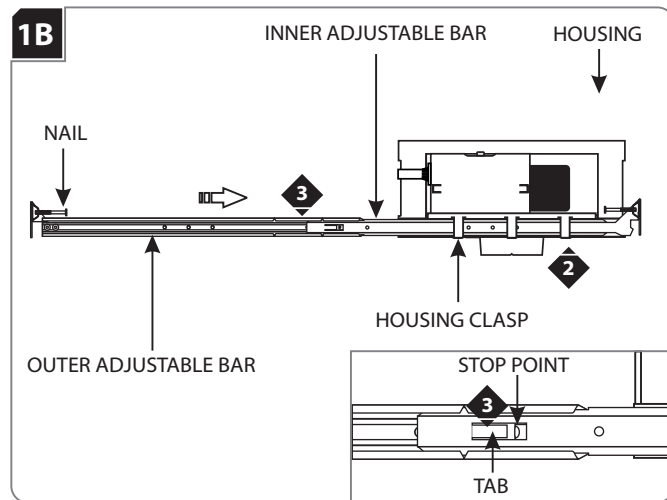

- 2 Slide the inner adjustable bar completely through the three housing clasps. Make sure the nail is on top.
- 3 Slide and push the outer adjustable bar completely onto the inner adjustable bar so that the tab clicks into place behind the stop point. This will prevent the adjustable bars from coming apart.
- 4 Repeat steps 2 & 3 for the other side of the housing.

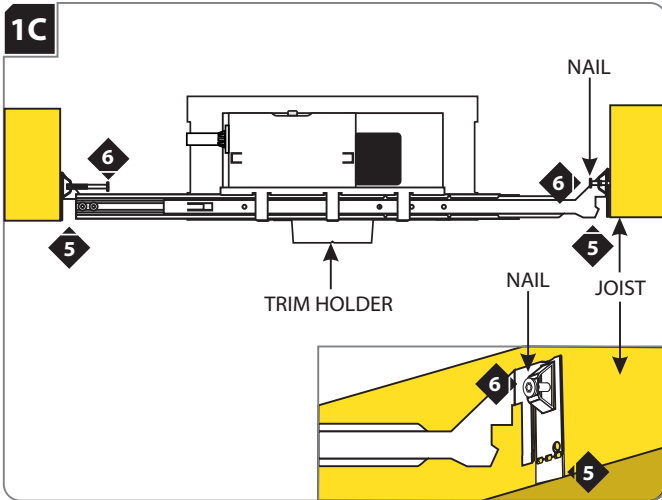

NOTE: The adjustable bars can be mounted to joists that are spaced 16" - 24" apart.

- 5 Align the bottom of the end plates with the bottom of the ceiling joists.
- 6 Level the adjustable bars and, with a hammer, tap the nails completely into the joists to secure the adjustable bars in place.

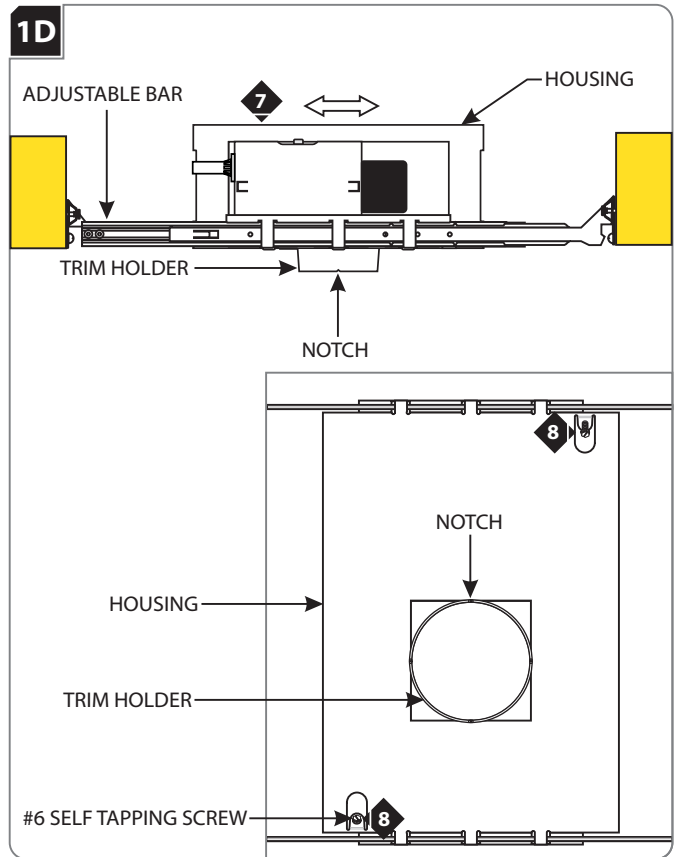

- 7 Adjust the trim holder position (horizontal position) by sliding the housing on adjustable bars.
- 8 When the desired location is achieved, tighten the two #6 self tapping screws to lock the housing onto the adjustable bars.

NOTE: Notches in trim holder can be used to align multiple housings using a laser or string.

Install the Housing with Butterfly Brackets

2A

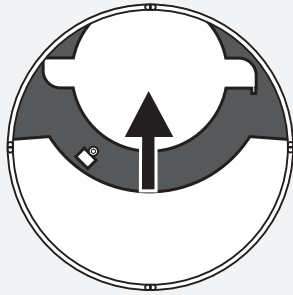

- 1 Gently push the lamp housing out of the way.

2B

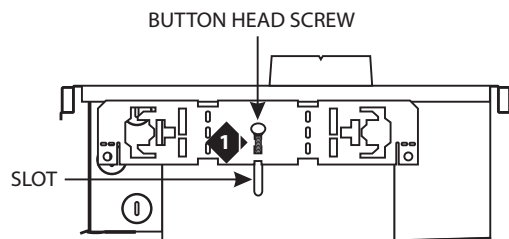

- 3 Place the button head screw through the square cut out of the butterfly bracket into the housing slot.

2C

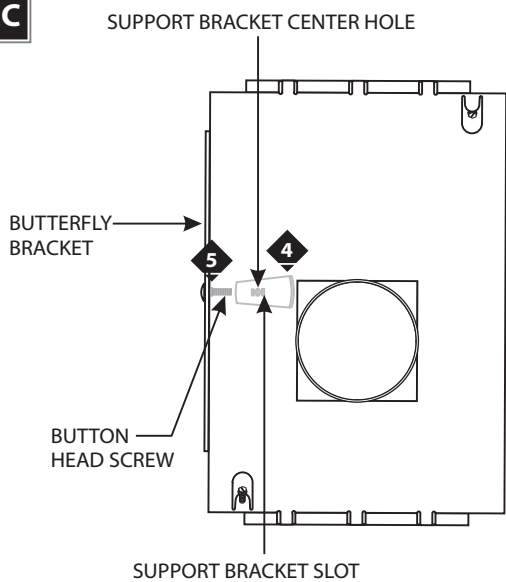

- 4 Place the support bracket center hole onto the button head screw.
- 5 Push the support bracket slots against the butterfly bracket tabs.

2D

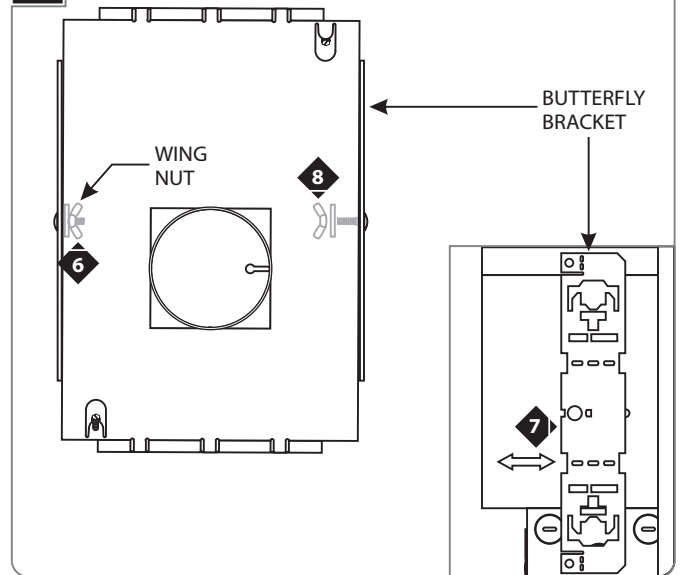

- 6 Attach the wing nut loosely to the button head screw.
- 7 Slide the butterfly bracket up or down to achieve the proper location. Tighten the wing nut to secure the butterfly bracket in place.
- 8 Repeat steps 3-7 for the other butterfly bracket.
- 9 Use the butterfly brackets to install the housing in accordance with local building and electrical codes.

NOTE: Notches in trim holder can be used to align multiple housings using a laser or string.

Connect Power to the Housing

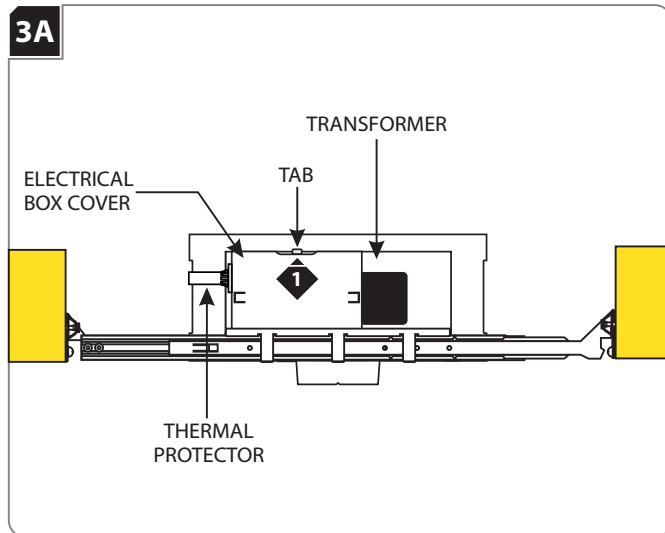

- 1 Push the tab on the housing electrical box up and remove the electrical box cover.

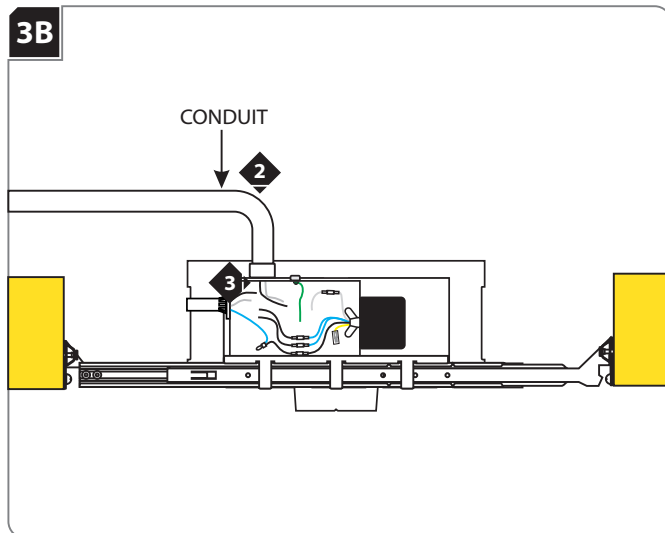

- 2 Install the conduit to the housing electrical box.
- 3 Run the power line wires into the housing electrical box.

NOTE: When a fixture is installed in a location that requires servicing from below the ceiling through the fixture aperture, the branch circuit connections need to be able to be brought out through the aperture. To accomplish this, an NM type cable in conjunction with snap-in/push-in connectors must be used and a 12" service loop must be left available outside of the fixture housing wiring compartment to allow additional branch circuit wiring to be pulled through the snap-in/push-in connector and extended out through the aperture below ceiling level.

WARNING: RISK OF FIRE: When using the housing electrical box for power feed through, use **MAX** 4 - #12 AWG, or 6 - #14 AWG branch circuit wires.

Toroidal Transformer - Go to Section 5

Electronic Transformer - Go to Section 6

Wire the Fixture (Toroidal Transformer)

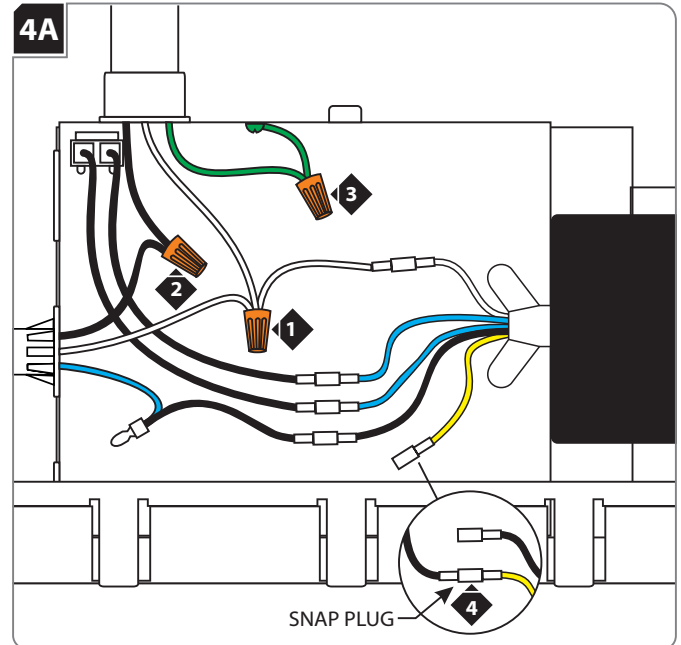

- 1 Connect the neutral power line wire to the white transformer wire and the white thermal protector with a wire nut.
- 2 Connect the black thermal protector wire to the hot power line wire with a wire nut.
- 3 Make sure that the housing is grounded in accordance with local electrical codes.
- 4 **If using a dimmer:** Disconnect the snap plug between the black transformer wire and the black thermal protector wire. Connect the yellow transformer wire snap plug to the blue thermal protector wire snap plug. **If necessary, make sure to cap the black transformer wire snap plug.**
- 5 Replace the electrical box cover. Make sure that the top edge of the cover snaps under the tabs.

Wire the Fixture (Electronic Transformer)

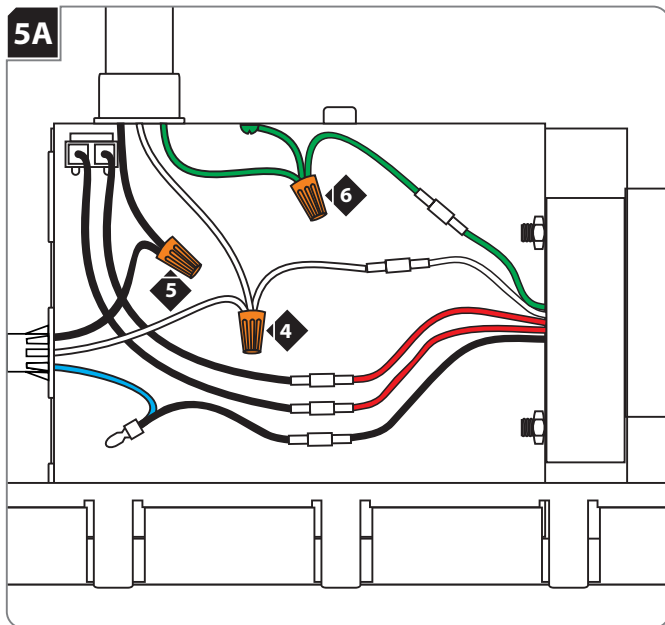

- 4 Connect the neutral power line wire to the white transformer wire and the white thermal protector wire with the wire nut.
- 5 Connect the hot power line wire to the black thermal protector wire with the wire nut.
- 6 Connect the fixture ground wire and the green transformer wire to a suitable ground according to local electrical codes.

Adjust the Lamp Housing

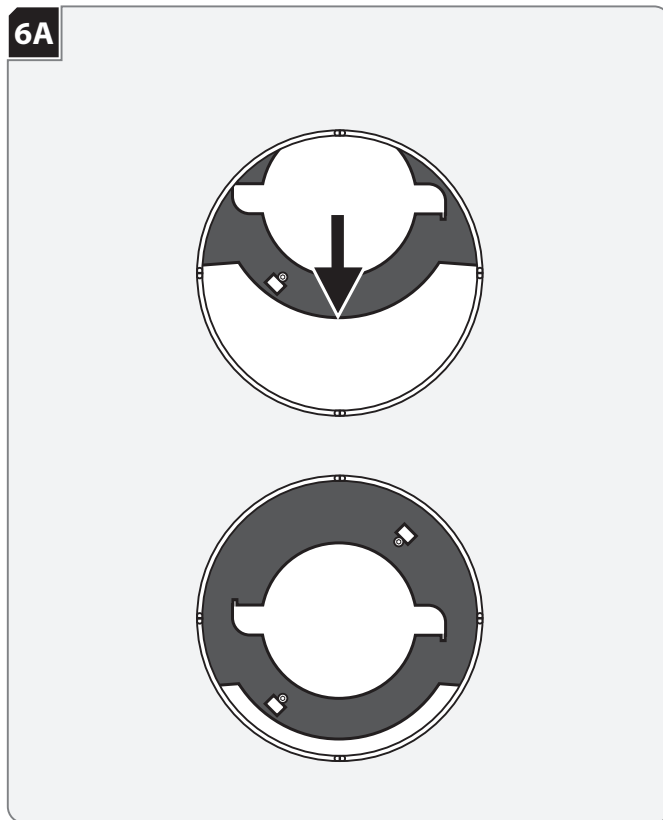

- 1 Ensure that the lamp housing is centered to the aperture by pulling it to the center of the housing. When centered the locking pin will be engaged.

Install the Lamp

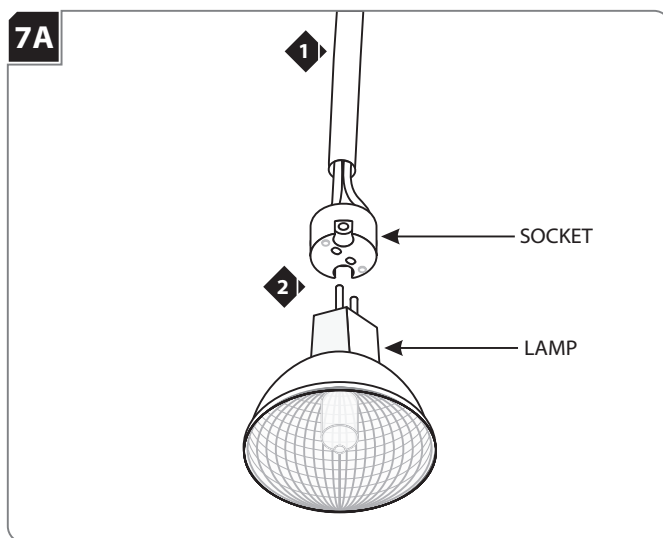

Use **MAX 50 Watt** Type MR16 Halogen Lamp.

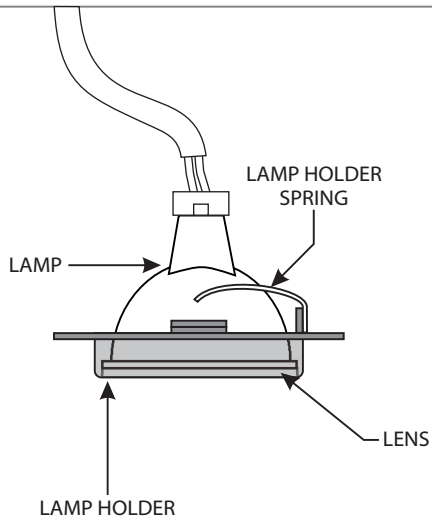

- 1 Pull the socket out of the housing.
- 2 Push the lamp pins completely into the socket holes.

7B

- 3 Ensure that the glass lens is properly inside the lamp holder.
- 4 Slide the lamp completely into the lamp holder spring so the lamp snaps into the lamp holder.

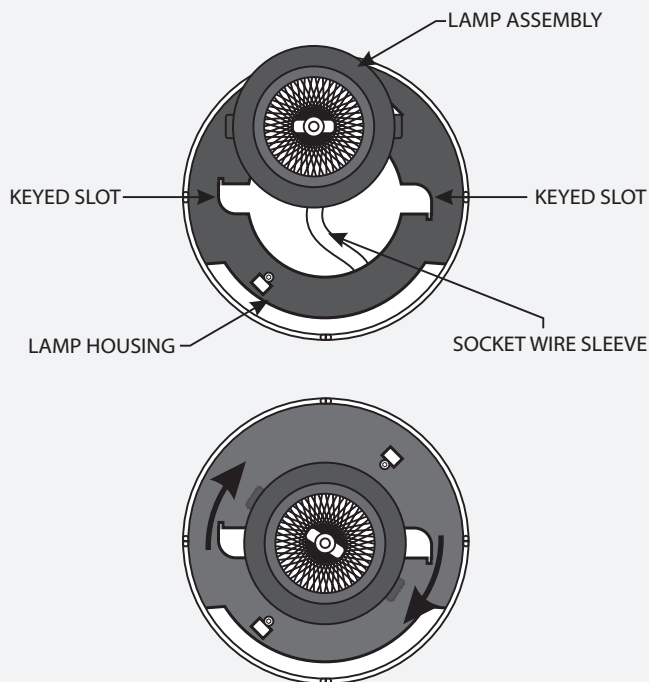
7C

- 5 Feed the socket wire sleeve back into the lamp housing and align the lamp assembly with the keyed slots on the lamp housing.
- 6 Place the lamp assembly into the lamp housing and rotate it until it locks into place.

Install the Drywall

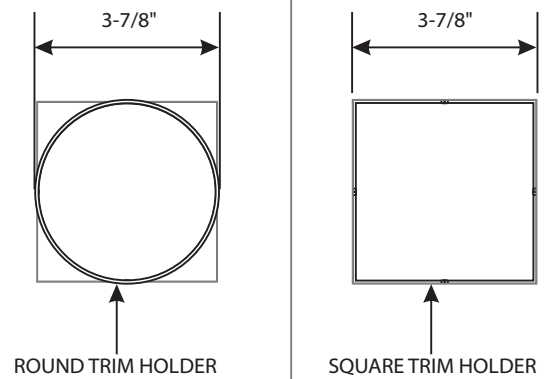
8A

- 1 For round trims, mark a 3-7/8" diameter circle on drywall. Cut out the marked section.
For square trims, mark a 3-7/8" square on drywall. Cut out the marked section.

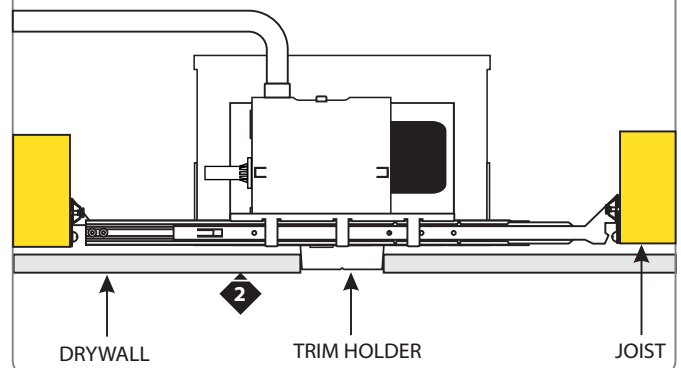
8B

- 2 Align the cut out section of drywall with the trim holder and install the drywall.

WARNING: Risk of Fire: The housing is not intended to be in contact with or covered with combustible materials and insulation. Do not install insulation within 3 inches of the housing sides or above in such a manner to entrap heat.

Install the Plaster Ring (for Flangeless Versions)

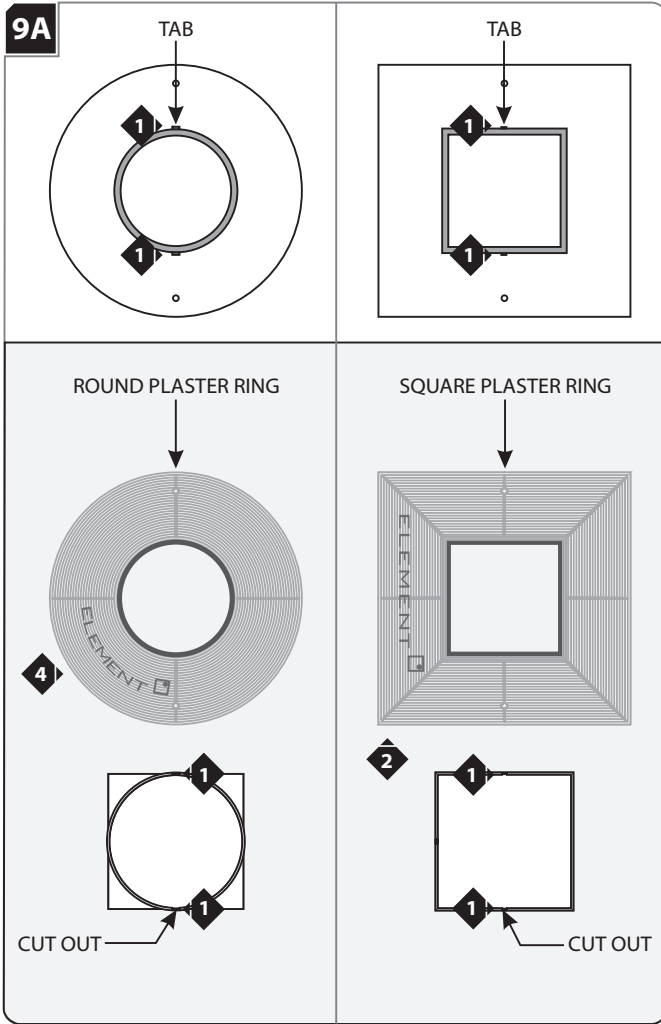

- 1 Line up the two tabs in back of the plaster ring with the two cut out sections of the trim holder inside edge.
- 2 Push the plaster ring tabs into the cut out sections of the trim holder edge.

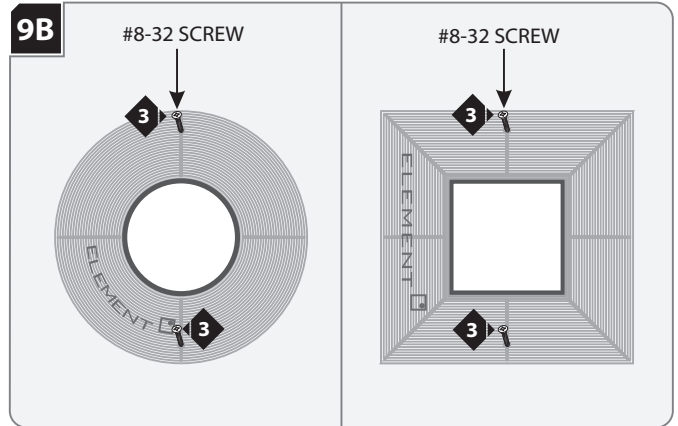

- 3 Secure the plaster ring in place with the two provided flat head #8-32 screws. Make sure that the screws penetrate through the drywall into the housing screw holes.

NOTE: Do not overtighten the screws!
Overtightening may bend the plaster ring, causing the plaster surface to come away from the drywall.

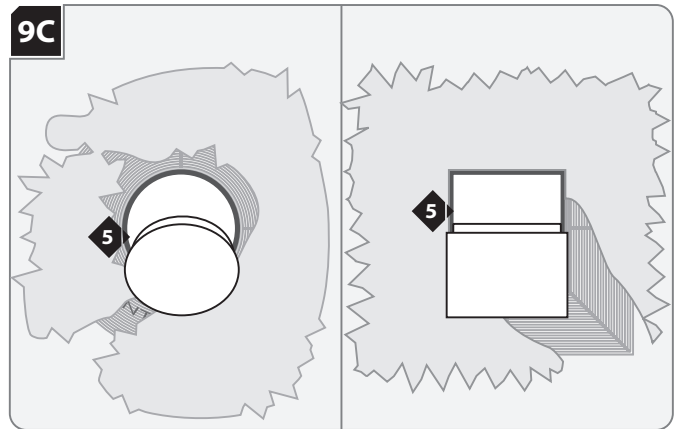

- 4 Plug the trim holder with the provided dust shield.
- 5 Properly plaster onto the plaster ring and drywall.

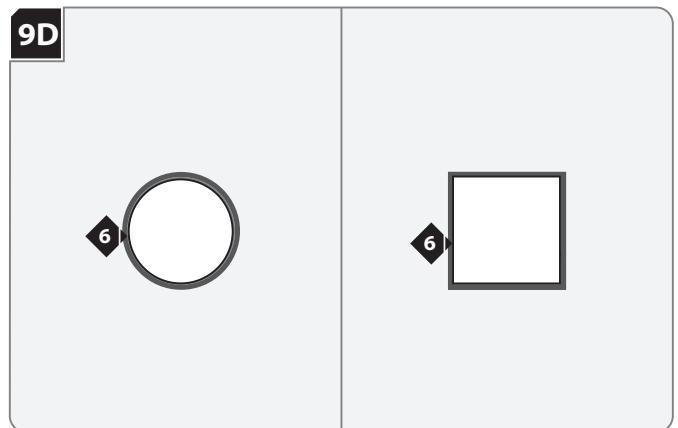

- 6 Finish around the trim to match drywall.



7400 Linder Ave., Skokie, IL 60077

T 847.410.4400 | F 847.410.4500

www.techlighting.com