

Round or Square Type IC Down Light Housing with Remote Transformer for Flangeless Trims

E3_L_-HDIR_ 1.6



HALOGEN MR16 - ROUND/SQUARE FLANGELESS

GENERAL PRODUCT INFORMATION:



For insulation applications above R25, no branch circuits allowed.

This instruction shows a typical installation.



CAUTION - RISK OF FIRE

This product must be installed in accordance with the applicable installation code by a person familiar with the construction and operation of the product and the hazards involved.

Use minimum 90°C supply conductors.

Install the Housing with Adjustable Bars

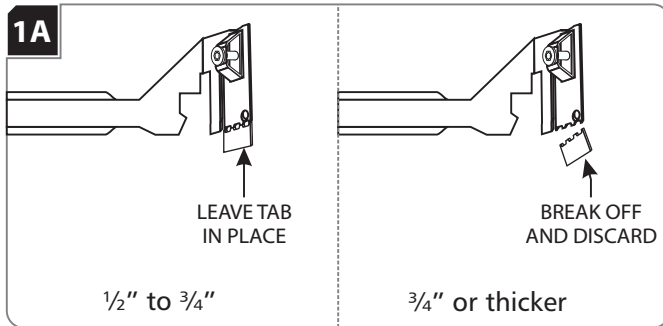

NOTE: Skip this section if installing the housing with butterfly brackets.

- 1 Keep Tab for ceiling 1/2" to 3/4" thick.**
 When using adjustable hanger bars with 1/2" to 3/4" thick ceilings, leave the tab of the hanger bars in place.
Break off Tab for ceiling 3/4" or thicker.
 When using adjustable hanger bars with 3/4" or thicker ceilings, remove the tab by bending it at the perforation.

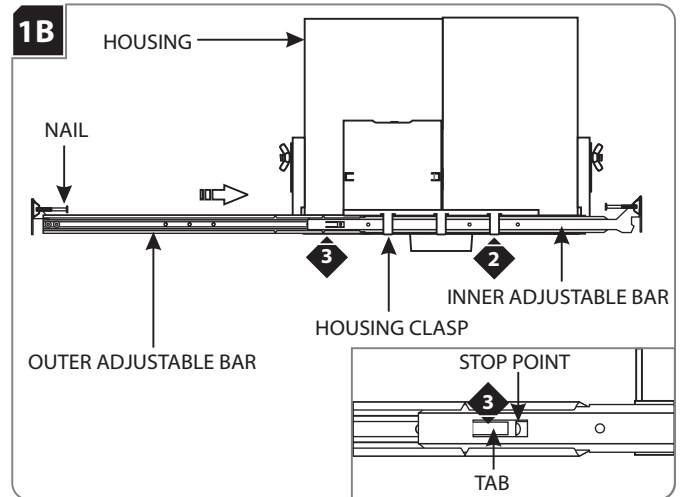

- 2** Slide the inner adjustable bar completely through the three housing clasps. Make sure the nail is on top.
- 3** Slide and push the outer adjustable bar completely onto the inner adjustable bar so that the tab clicks into place behind the stop point. This will prevent the adjustable bars from coming apart.
- 4** Repeat steps 2 & 3 for the other side of the housing.

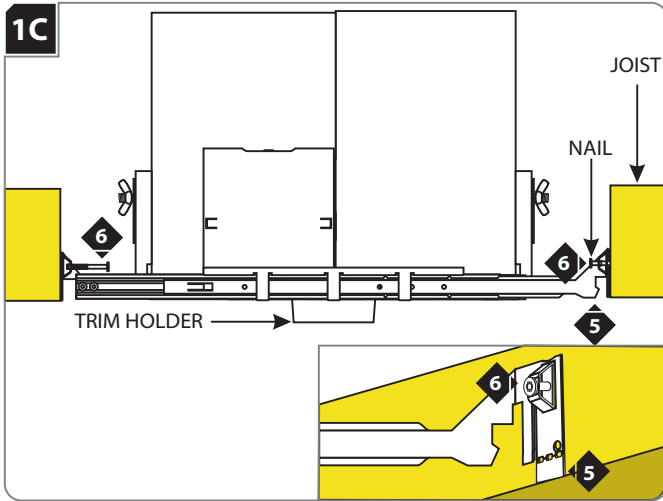

NOTE: The adjustable bars can be mounted to joists that are spaced 16" - 24" apart.

- 5 Align the bottom of the end plates with the bottom of the ceiling joists.
- 6 Level the adjustable bars and, with a hammer, tap the nails completely into the joists to secure the adjustable bars in place.

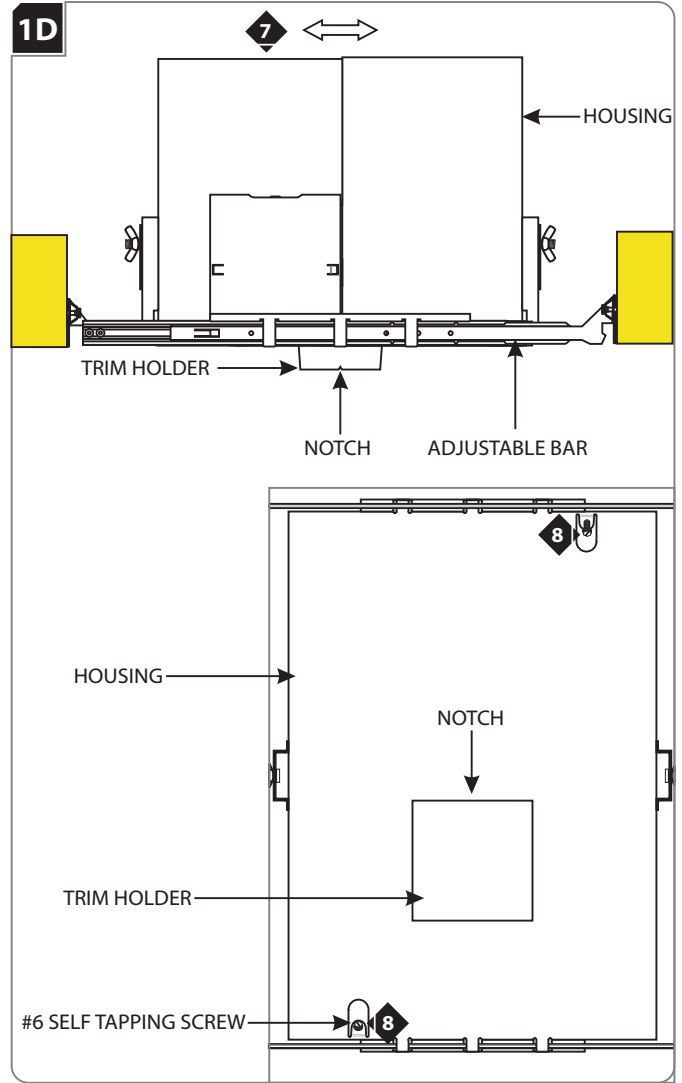

- 7 Adjust the trim holder position (horizontal position) by sliding the housing on adjustable bars.
- 8 When the desired location is achieved, tighten the two #6 self tapping screws to lock the housing onto the adjustable bars.

NOTE: Notches in trim holder can be used to align multiple housings using a laser or string.

Install the Housing with Butterfly Brackets

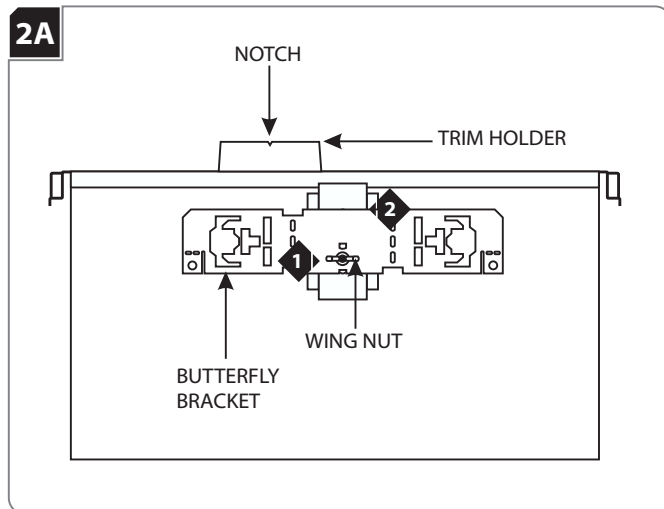

NOTE: Skip this section if installing the housing with adjustable bars.

- 1 Slightly loosen the wing nut to slide the butterfly bracket up or down.
- 2 After achieving the proper location, tighten the wing nut to secure the butterfly bracket in place.
- 3 Repeat steps 1 and 2 on for the other butterfly bracket.
- 4 Utilize the butterfly brackets to install the housing in accordance with local electrical codes.

NOTE: Notches in trim holder can be used to align multiple housings using a laser or string.

Connect Power to the Housings

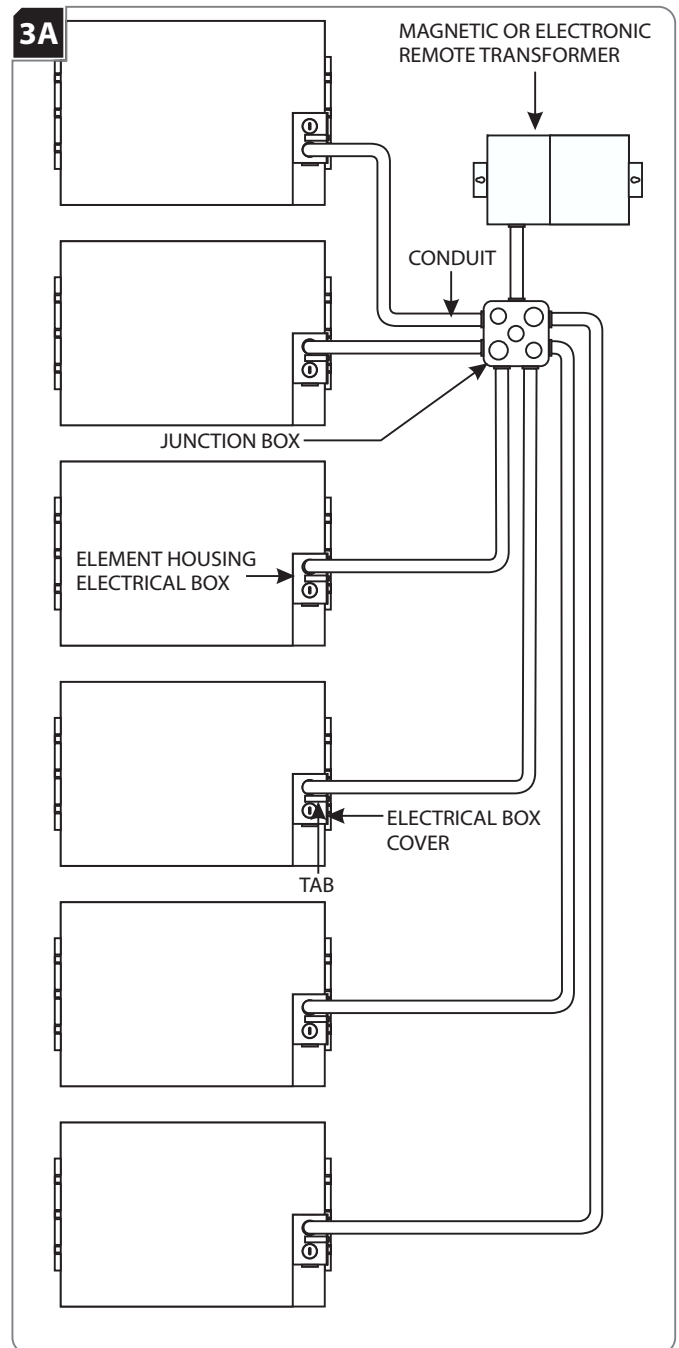

- 1 For each Element housing, push the tab on the housing electrical box up and remove the electrical box cover.
- 2 Run conduits from remote transformer (via a junction box) to the each Element housing electrical box.
- 3 Branch the low voltage wires from the remote transformer (via junction box) to Element housings. For proper low voltage wire size, refer to the "Low Voltage Wire Size Table" provided in the remote transformer instruction.

WARNING: RISK OF FIRE: When using the housing electrical box for power feed through, use **MAX** 4 - #12 AWG, or 6 - #14 AWG branch circuit wires.

Install the Lamp & Lens Accessories

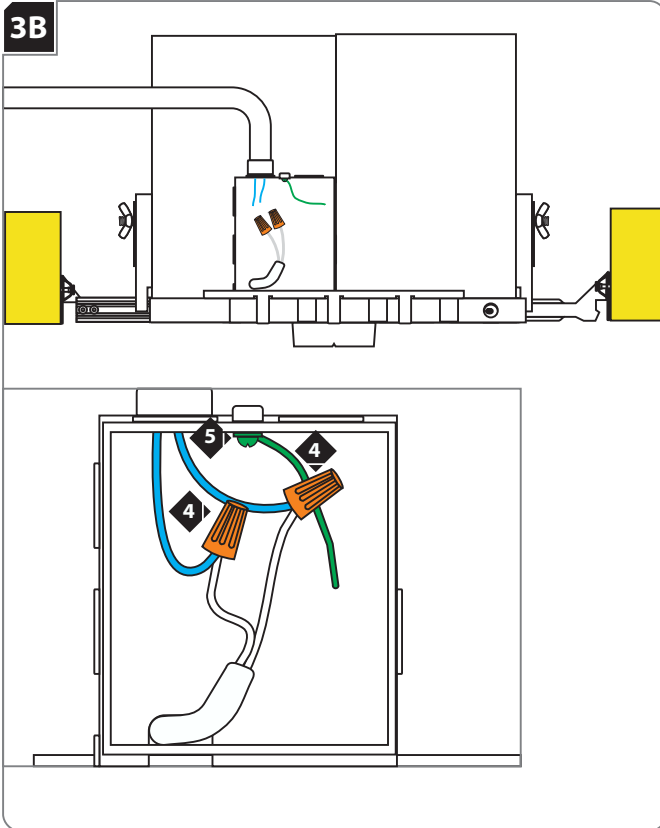

- 4 Connect each low voltage wire to one socket wire with a wire nut.
- 5 Make sure that housing is grounded in accordance with local electrical codes.

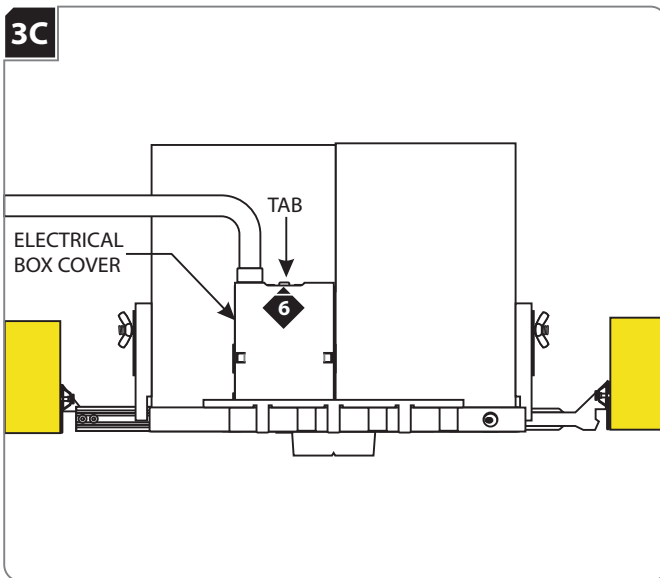

- 6 Replace the electrical box cover. Make sure that the top edge of the cover snaps under the tab.
- 7 Repeat steps 4 through 6 for the remaining Element housings.

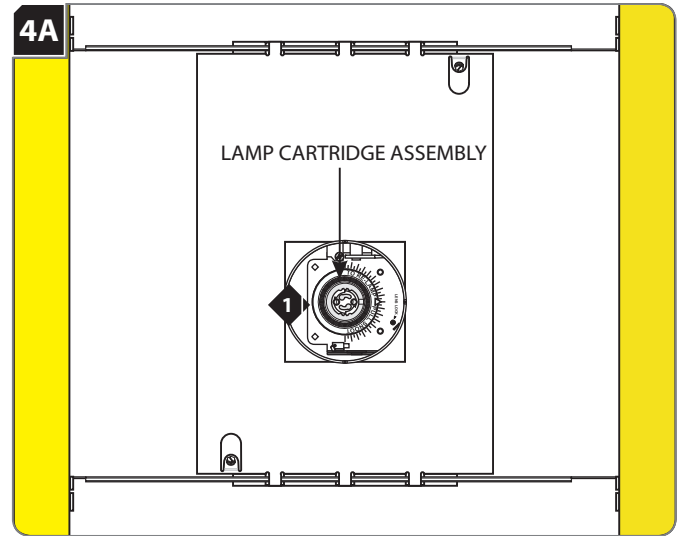

- 1 Pull the snoot to remove the lamp cartridge assembly.

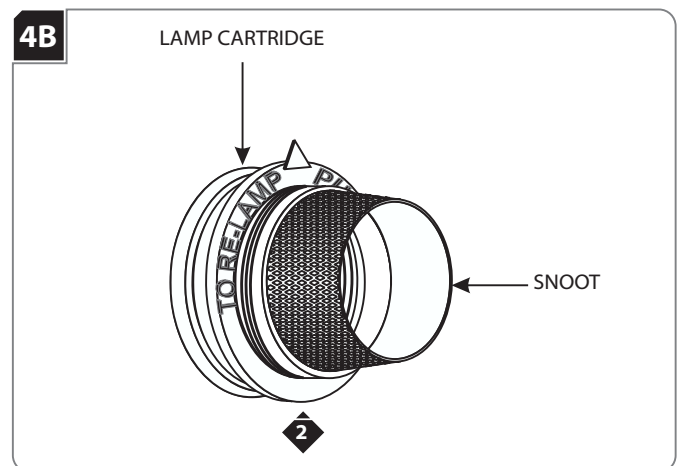

- 2 Unscrew the snoot from the lamp cartridge.

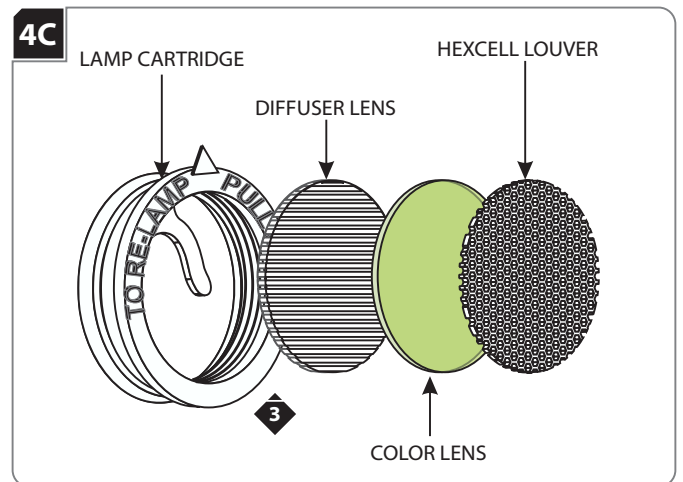

- 3 Place a maximum of three accessories (optional) into the lamp cartridge.

4D

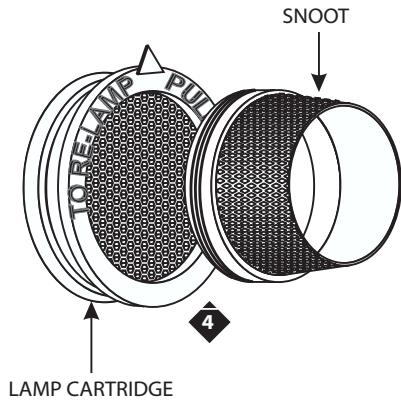

- 4 Replace and tighten the snoot completely to the lamp cartridge.

4E

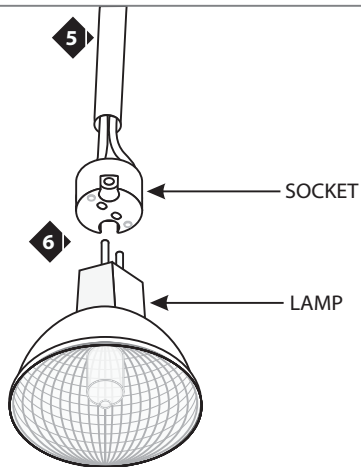

Use **MAX 75** Watt Type MR16 Halogen Lamp.



- 5 Pull out the socket from the lamp housing.
- 6 Push the lamp pins completely into the socket holes.

4F

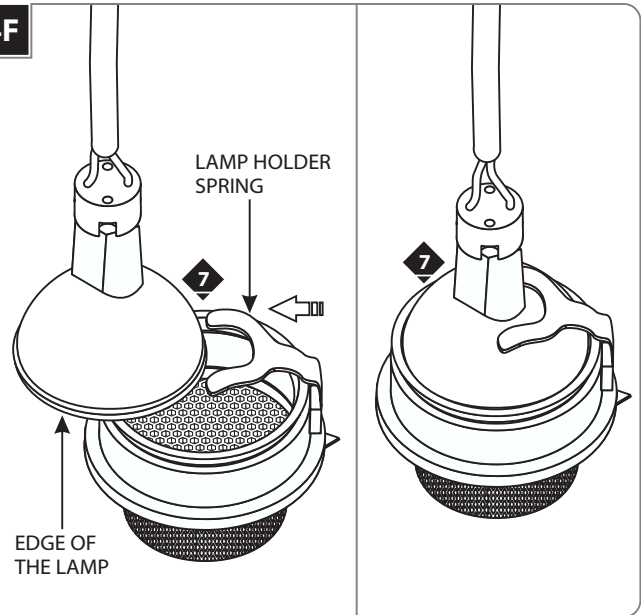

- 7 Slide the lamp holder spring completely onto back of the MR16 lamp so that the edge of the lamp snaps into the lamp cartridge assembly.

4G

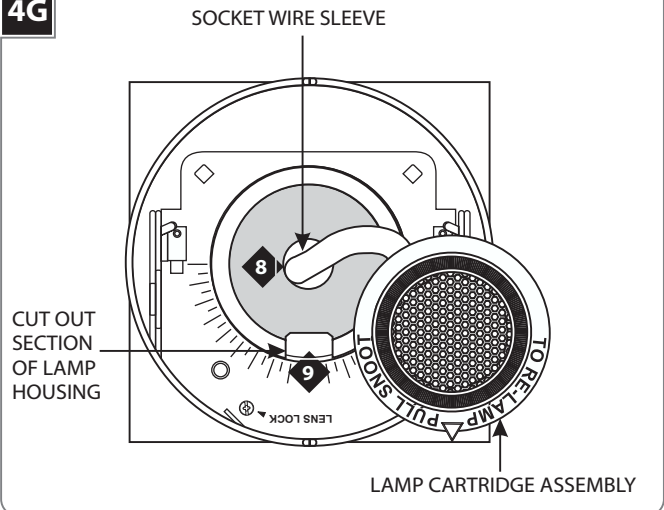

- 8 Feed the socket wire sleeve back into the lamp housing.
- 9 Align the arrow indicator on the lamp cartridge assembly with the cut out section of the lamp housing. Push to snap the lamp cartridge assembly into the lamp housing.

NOTE: Before installing drywall, it is recommended to power up and run the Element fixture(s) for 10 minutes to make sure that all electrical connections are tight and secure.

Install Drywall and Plaster Ring

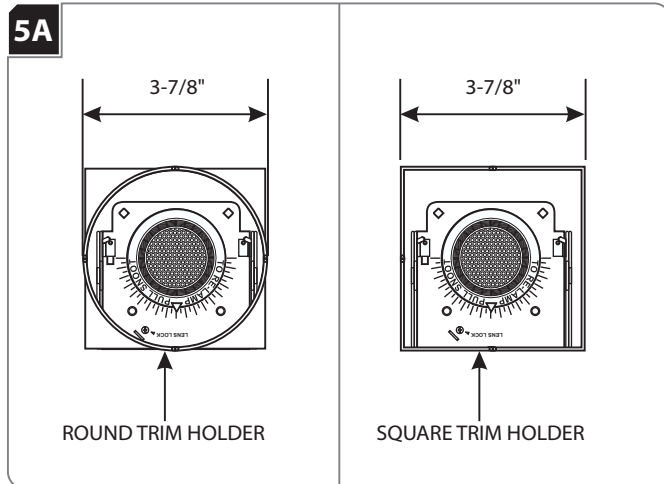

- 1** For round trims, mark a 3-7/8" diameter circle on drywall. Cut out the marked section.
For square trims, mark a 3-7/8" square on drywall. Cut out the marked section.

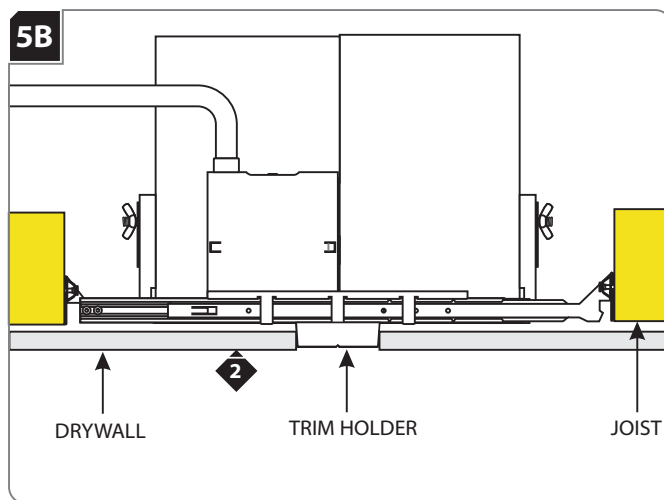

- 2** Align the cut out section of drywall with the trim holder and install the drywall.

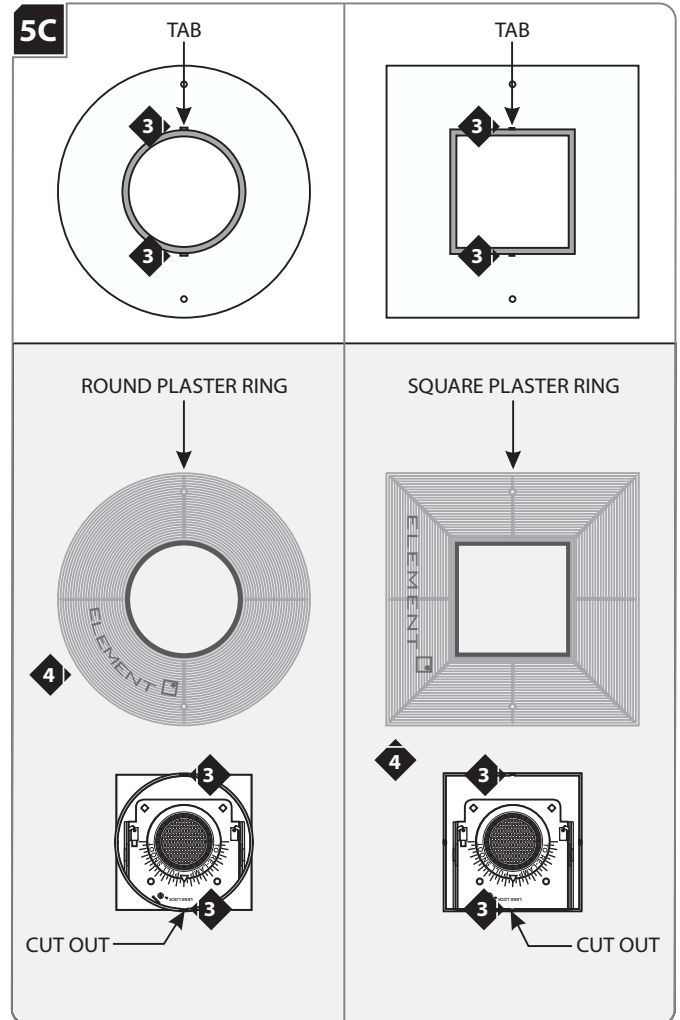

- 3** Line up the two tabs in back of the plaster ring with the two cut out sections of the trim holder inside edge.
4 Push the plaster ring tabs into the cut out sections of the trim holder edge.

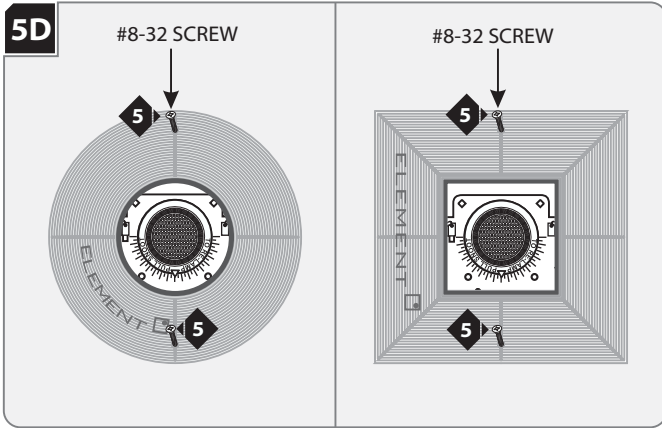

- 5 Secure the plaster ring in place with the two provided flat head #8-32 screws. Make sure that the screws penetrate through the drywall into the housing screw holes.

NOTE: Do not overtighten the screws!
Overtightening may bend the plaster ring, causing the plaster surface to come away from the drywall.

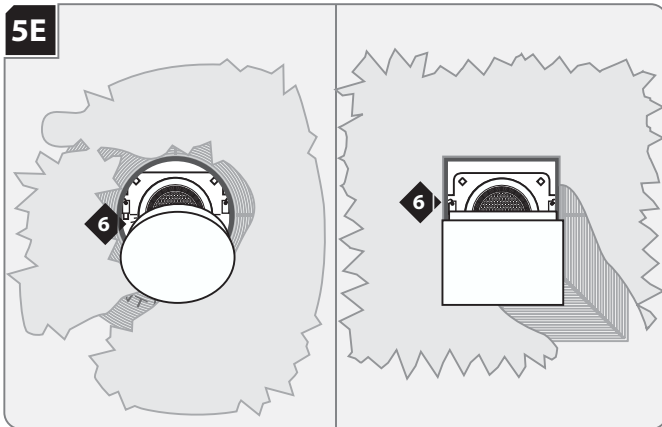

- 6 Plug the trim holder with the provided dust shield.
7 Properly plaster onto the plaster ring and drywall.

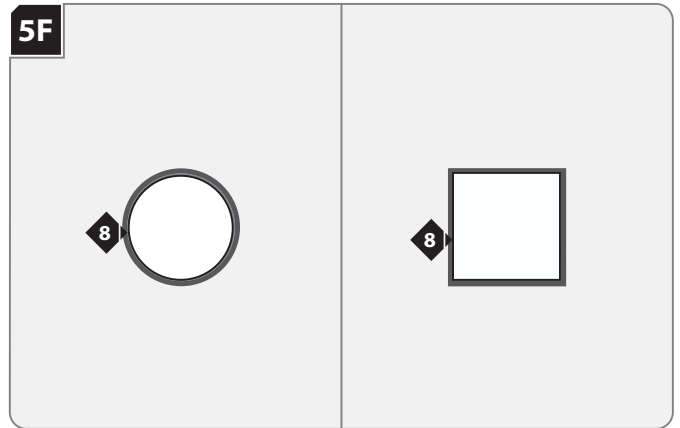

- 8 Finish around the trim to match drywall.

SAVE THESE INSTRUCTIONS!



7400 Linder Ave, Skokie, IL 60077
847.410.4400

www.element-lighting.com

© 2016 Tech Lighting, L.L.C. All rights reserved. The "Element" graphic is a registered trademark of Element. Element reserves the right to change specifications for product improvements without notification.

A Generation Brands Company